

# PARTS, OPERATION AND MAINTENANCE MANUAL for AIR CHAIN HOIST MODELS\*

**ML250K**  
250 kg (1/4 ton)

**ML500K**  
500 kg (1/2 ton)

**ML1000K**  
1000 kg (1 ton)

**ML250KR**  
250 kg (1/4 ton)  
Spark Resistant

**ML500KR**  
500 kg (1/2 ton)  
Spark Resistant

**ML250KS**  
250 kg (1/4 ton)  
Slow Speed

**ML500KS**  
500 kg (1/2 ton)  
Slow Speed

**ML1000KS**  
1000 kg (1 ton)  
Slow Speed

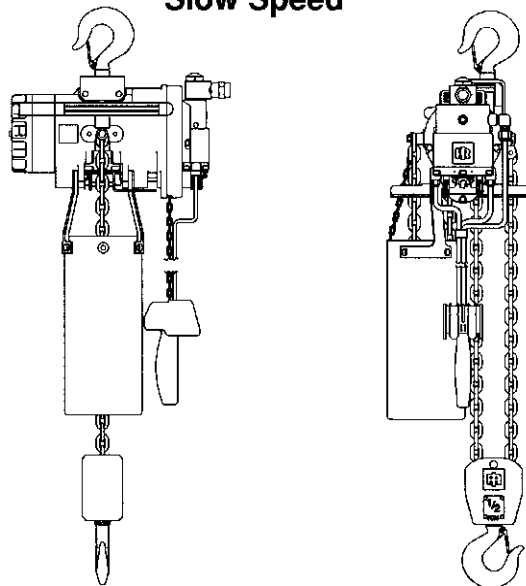

(Dwg. MHTPA0456)

\* Capacities of hoists are in metric tons (1 metric ton = 2200 lbs.)

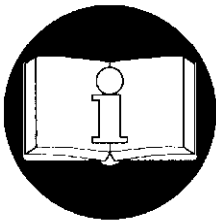

**READ THIS MANUAL BEFORE USING THESE PRODUCTS.** This manual contains important safety, installation, operation and maintenance information. Make this manual available to all persons responsible for the operation, installation and maintenance of these products.

## **⚠ WARNING**

**Do not use this hoist for lifting, supporting, or transporting people or lifting or supporting loads over people.**

**Always operate, inspect and maintain this hoist in accordance with American National Standards Institute Safety Code ( ASME B30.16) and any other applicable safety codes and regulations.**

**Refer all communications to the nearest Ingersoll-Rand Material Handling Office or Distributor.**

Form P6554  
Edition 9  
June 1994  
03531324  
© 1994 Ingersoll-Rand Company

**INGERSOLL-RAND®**  
**MATERIAL HANDLING**

## SAFETY INFORMATION

This manual provides important information for all personnel involved with the safe installation, operation and proper maintenance of this product. Even if you feel you are familiar with this or similar equipment, you should read and understand this manual before operating the product.

### Danger, Warning, Caution and Notice

Throughout this manual there are steps and procedures which, if not followed, may result in a injury. The following signal words are used to identify the level of potential hazard.

#### DANGER

Danger is used to indicate the presence of a hazard which *will* cause *severe* injury, death, or substantial property damage if the warning is ignored.

#### WARNING

Warning is used to indicate the presence of a hazard which *can* cause *severe* injury, death, or substantial property damage if the warning is ignored.

#### CAUTION

Caution is used to indicate the presence of a hazard which *will* or *can* cause *minor* injury or property damage if the warning is ignored.

#### NOTICE

Notice is used to notify people of installation, operation, or maintenance information which is important but not hazard-related.

### Safety Summary

#### WARNING

- Do not use this hoist or attached equipment for lifting, supporting, or transporting people or lifting or supporting loads over people.
- Powered hoists are designed to provide a 5 to 1 safety factor. The supporting structures and load-attaching devices used in conjunction with this hoist must provide adequate support to handle all hoist operations plus the weight of the hoist and attached equipment. This is the customer's responsibility. If in doubt, consult a registered structural engineer.

#### NOTICE

- Lifting equipment is subject to different regulations in each country. These regulations may not be specified in this manual.

The National Safety Council, Accident Prevention Manual for Industrial Operations, Eighth Edition and other recognized safety sources make a common point: Employees who work near cranes or assist in hooking on or arranging a load should be instructed to keep out from under the load. From a safety standpoint, one factor is paramount: conduct all lifting operations in such a manner that if there were an equipment failure, no personnel would be injured. This means keep out from under a raised load and keep out of the intended path of any load.

Ingersoll-Rand Material Handling hoists are manufactured in accordance with the latest ASME B30.16 standards.

The Occupational Safety and Health Act of 1970 generally places the burden of compliance with the owner/employer, not the manufacturer. Many OSHA requirements are not concerned or connected with the manufactured product but are, rather, connected with the final installation. It is the owner's responsibility and user's responsibility to determine the suitability of a product for any particular use. It is recommended that all applicable industry, trade association, federal, state and local regulations be checked. Read all operating instructions and warnings before operation.

**Rigging:** It is the responsibility of the operator to exercise caution, use common sense and be familiar with proper rigging techniques. See ASME B30.9 for rigging information, American National Standards Institute, 1430 Broadway, New York, NY 10018.

This manual has been produced by **Ingersoll-Rand** to provide dealers, mechanics, operators and company personnel with the information required to install, operate, maintain and repair the products described herein.

It is extremely important that mechanics and operators be familiar with the servicing procedures of these products, or like or similar products, and are physically capable of conducting the procedures. These personnel shall have a general working knowledge that includes:

1. Proper and safe use and application of mechanics common hand tools as well as special **Ingersoll-Rand** or recommended tools.
2. Safety procedures, precautions and work habits established by accepted industry standards.

**Ingersoll-Rand** can not know of, nor provide all the procedures by which product operations or repairs may be conducted and the hazards and/or results of each method. If operation or maintenance procedures not specifically recommended by the manufacturer are conducted, it must be ensured that product safety is not endangered by the actions taken. If unsure of an operation or maintenance procedure or step, personnel should place the product in a safe condition and contact supervisors and/or the factory for technical assistance.

## SAFE OPERATING PROCEDURES

The following warnings and operating instructions have been adapted in part from American National (Safety) Standard ASME B30.16 and are intended to avoid unsafe operating practices which might lead to personal injury or property damage.

**Ingersoll-Rand** recognizes that most companies who use hoists have a safety program in force in their plants. In the event you are aware that some conflict exists between a rule set forth in this publication and a similar rule already set by an individual company, the more stringent of the two should take precedence.

Safe Operating Instructions are provided to make an operator aware of dangerous practices to avoid and are not necessarily limited to the following list. Refer to specific sections in the manual for additional safety information.

1. Read the manufacturer's operating instructions before operating the hoist.
2. Never lift a load greater than the rated capacity of the hoist (unless for test purposes).
3. Never use the load chain as a sling.
4. Never operate the hoist with twisted, kinked or damaged chain.
5. Be certain the load is properly seated in the saddle of the hook.
6. Do not use load chains as a ground for welding. Do not attach a welding electrode to a hoist or sling chain.
7. Do not use the up and down stops as a means of stopping a hoist. The up and down stops are emergency devices only. Keep hands and clothing free from the throttle lever.
8. Do not leave a load suspended for extended periods.
9. Always stand clear of the load path.
10. Never use the hoist for lifting or lowering people, and never stand on a suspended load.
11. Never carry loads over people.
12. Before each shift, check the hoist for wear or damage. Check brakes, limit stops, etc.
13. Periodically, inspect the hoist thoroughly and replace worn or damaged parts.
14. Follow the lubrication instructions.
15. Do not attempt to repair load chain or hooks. Replace them when they become worn or damaged.
16. Never operate a hoist when the load chain is not centered under the hook. Do not "side pull" or "yard".
17. Always rig the hoist properly and carefully.
18. Ease the slack out of the load chain when starting a lift. Do not jerk the hoist load.
19. Keep the load chain clean and well lubricated. Do not drag the load chain or hook on the floor.
20. Be certain there are no objects in the way of a moving load.
21. Be certain the air supply is shut off before performing maintenance on the hoist.
22. Do not swing a suspended load.
23. Keep the load block overhead when not in use.
24. Properly secure hoist before leaving it unattended.
25. Only allow personnel trained in safety and operation on this product to operate the hoist.
26. Avoid collision or bumping of hoists.
27. Do not operate a hoist if you are not physically fit to do so.
28. Pay attention to the load at all times when operating a hoist.
29. Never splice a hoist chain by inserting a bolt between links or by any other means.
30. Do not force a chain or hook into place by hammering, and never insert the point of the hook into a chain link.
31. Do not allow the chain to be exposed to extremely cold weather. Do not apply loads to a cold chain.

## WARNING TAGS AND LABELS

Each hoist is supplied from the factory with the warning tag and label shown. If the tag or label are not attached to your hoist, order a new tag or label and install it. See parts list in parts section. Read and obey all warnings and other safety information attached to this hoist. Tag and label may not be shown actual size.



**WARNING**

**Failure to follow these warnings may result in death, severe injury or property damage:**

- Do not operate this hoist before reading operation and maintenance manual.
- Do not lift people or loads over people.
- Do not lift more than rated load.
- Do not operate unless load is centered under hoist.
- Do not operate with twisted, kinked or damaged chain or wire rope.
- Do not operate a damaged or malfunctioning hoist.
- Do not remove or obscure warning labels.
- Do not operate a wire rope hoist when rope is not properly seated in its groove.

Read the latest edition of ASME/ANSI B30.16 and National Electric Code (ANSI/NFPA 70). Comply with other federal, state and local rules.

P/N 71059612/B for air and electric chain and wire rope hoists

**INGERSOLL-RAND**  
 MATERIAL HANDLING

## SPECIFICATIONS

**Table 1**

Hoist Model No.	Rated Capacity (kg)	No. Chain Falls	Speed with Rated Load				Speed with Half Load				Speed with No Load			
			fpm		m/m		fpm		m/m		fpm		m/m	
			up	down	up	down	up	down	up	down	up	down	up	down
ML250KS	250	1	40	90	12.2	27.4	53	71	16.1	21.6	71	53	21.6	16.1
ML250K			101	117	30.8	35.7	145	111	44.2	33.8	171	99	52.1	30.1
ML250KR			26	38	7.9	11.6	34	36	10.4	11.0	42	30	12.8	9.1
ML500KS	500	1	22	66	6.7	20.1	30	44	9.1	13.4	44	32	13.4	9.7
ML500K			55	97	16.8	29.6	80	72	24.4	22.0	106	59	32.3	18.0
ML500KR		2	13	20	4.0	6.1	17	18	5.2	5.5	21	15	6.4	4.6
ML1000KS	1000	2	11	33	3.4	10.0	15	22	4.6	6.7	22	16	6.7	4.9
ML1000K			28	49	8.5	14.9	40	36	12.2	11.0	53	30	16.1	9.1

Performance figures based on 70 CFM (45 CFM for MLKS and MLKR Hoists) at 90 psi (620 kPa) air supply at hoist inlet. Pendant control models use approximately 4 SCFM more air.

## Model Code Explanation

Example:

**ML500KR-2C10-5BZ**

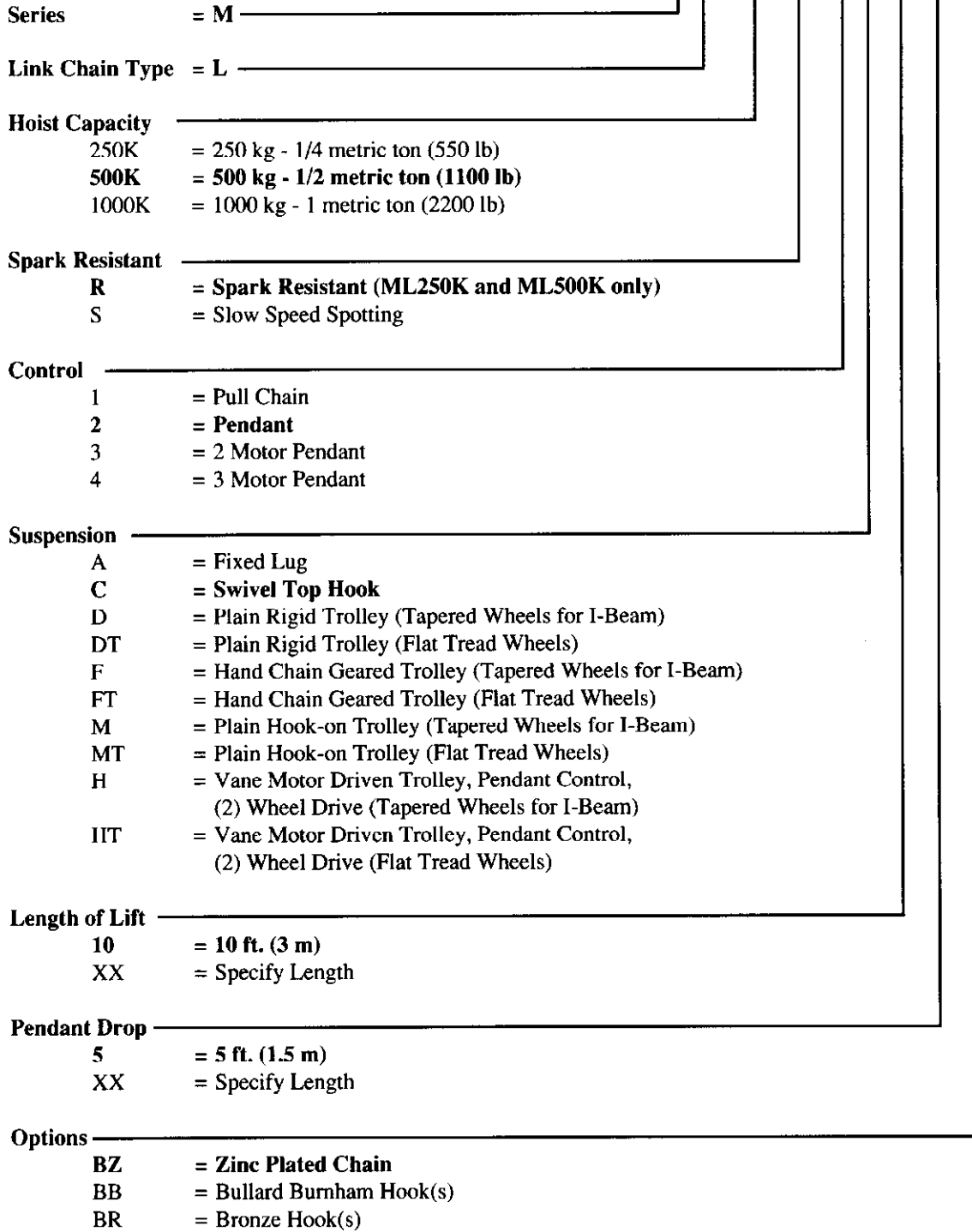

## INSTALLATION

Prior to installing the hoist, carefully inspect it for possible shipping damage.  
Hoists are supplied fully lubricated from the factory.  
Lubrication of the load chain is recommended before initial hoist operation.

### ⚠ CAUTION

• Owners and users are advised to examine specific, local or other regulations, including American National Standards Institute and/or OSHA Regulations which may apply to a particular type of use of this product before installing or putting hoist to use.

### ⚠ WARNING

• A falling load can cause injury or death. Before installing, read "SAFETY INFORMATION".

### Hoist

Make certain your hoist is properly installed. A little extra time and effort in so doing can contribute a lot toward preventing accidents and helping you get the best service possible.

Always make certain the supporting member from which the hoist is suspended is strong enough to support the weight of the hoist plus the weight of a maximum rated load plus a generous factor of at least 500% of the combined weights.

If the hoist is suspended by a top hook, the supporting member should rest completely within the saddle of the hook and be centered directly above the hook shank. Do not use a supporting member that tilts the hoist to one side or the other.

### Hook Mounted Hoist Installation

Place hook over mounting structure. Make sure hook latch is engaged.

### Trolley Mounted Hoist Installation

(Refer to Dwg. TPA825-2)

When installing a trolley on a beam, measure the beam flange and temporarily install the trolley on the hoist to determine the exact distribution and arrangement of the spacers. The distance between the wheel flanges should be 3/16 in. to 1/4 in. (4.76 mm to 6.35 mm) greater than the width of the beam flange. The number of spacers (257) between the trolley side plate (250) and the mounting lug on the hoist must be the same in all four locations in order to keep the hoist centered under the I-beam. The remaining

spacers must be equally distributed on the outside of the side plates. (For additional information refer to Installation and Maintenance Manual Form P6609 for Vane Motor Driven Trolleys.)

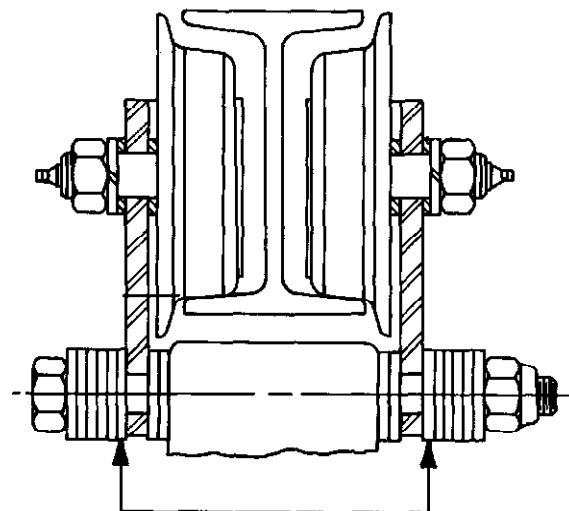

1 SPACER MINIMUM  
REQUIRED  
(SEE INSTRUCTIONS)

MLK Hoist Plain Rigid Trolley

(Dwg. TPD909)

### ⚠ WARNING

• At least one Mounting Spacer (257) must be used between the head of each Trolley Bracket Bolt (255) and the Trolley Bracket (250) and between each Trolley Bolt Nut (256) and the Trolley Bracket. Failure to do this could cause the hoist to fall when used improperly.

Torque the Trolley Bolt Nuts (256) to 150 ft-lb (203 N.m).

When installing the hoist and trolley on the beam, make certain the side plates are parallel and vertical. After installation, operate the trolley over the entire length of the beam with a capacity load suspended 4 to 6 inches (10 to 15 cms) off the floor.

### ⚠ CAUTION

• To avoid an unbalanced load which may damage the trolley, the hoist must be centered under the trolley.

### NOTICE

• Trolley wheels ride on the top of the lower flange of the beam.

## Chain Container

When installing a fabric chain container on an MLK hoist, refer to drawings TPB605-2 and TPD580 in the parts section.

### NOTICE

- Make certain to adjust the balance chain so that the chain container does not contact the load chain.
- Allow chain to pile naturally in the chain container. Piling the chain carelessly into the container by hand may lead to kinking or twisting that will jam the hoist.

1. Check the chain container size to make sure the length of load chain is within the capacity of the chain container. Replace with a larger chain container, if required.
2. Attach the chain container to the hoist.
3. Run bottom block to lowest point and run hoist in up direction to feed the chain back into the container.

## Air System

The supply air must be clean, lubricated and free from water or moisture. A minimum of 90 psi (6.2 bar/620 Kpa) at the hoist motor is required to provide rated hoist capacity.

### Air Lines

The inside diameter of the hoist air supply lines must not be smaller than 1/2 in. (13 mm) based on a maximum of 50 ft. (15 m) between the air supply and the hoist. Contact the factory for recommended air line sizes for distances greater than 50 ft. (15 m). Before making final connections, all air supply lines should be purged before connecting to unit inlet. Supply lines should be as short and straight as installation conditions will permit. Long transmission lines and excessive use of fittings, elbows, tees, globe valves etc. cause a reduction in pressure due to restrictions and surface friction in the lines. If quick-disconnect fittings are used at the inlet of the hoist, they must have at least a 3/8 in. (9.5 mm) air passage. Use of smaller fittings will reduce performance.

### NOTICE

- Always use an air line filter and lubricator with an MLK hoist.

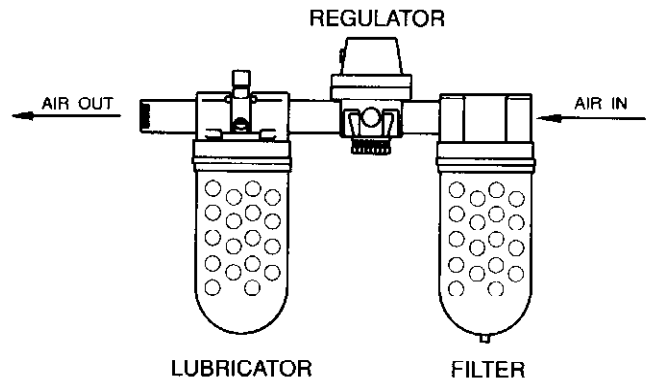

(Dwg. MHTPA0191)

### Air Line Lubricator

(Ref. Dwg. MHTPA0191)

Always use an air line lubricator with these hoists. Use a lubricator having an inlet and outlet at least as large as the inlet on the hoist motor. Install the air line lubricator as close to the air inlet on the hoist motor as possible. Refer to "ACCESSORIES" in the parts section for the recommended Filter-Lubricator-Regulator.

### CAUTION

- Lubricator must be located no more than 10 ft. (3 m) from the motor.

The air line lubricator should be replenished daily and set to provide lubrication at a minimum rate of 1 to 3 drops per minute adjusted at maximum hoist speed, of SAE 10W oil or a good grade of hydraulic oil. A fine mist will be exhausted from the throttle control valve when the air line lubricator is functioning properly.

### CAUTION

- Do not use automotive type detergent oil. Detergents will delaminate the motor vanes and cause premature failure.

### Air Line Filter

(Ref. Dwg. MHTPA0191)

It is recommended that an air line strainer/filter be installed as close as practical to the motor air inlet port to prevent dirt from entering the motor. The strainer/filter should provide 10 micron filtration and include a moisture trap. Clean the strainer/filter monthly to maintain its operating efficiency.

### Moisture in Air Lines

Moisture that reaches the air motor through the supply lines is the chief factor in determining the length of time between service overhauls. Moisture traps can help to eliminate moisture. Other methods, such as an air receiver which collects moisture before it reaches the motor or an aftercooler at the compressor that cools the air prior to distribution through the supply lines, are also helpful.



- Shut off air supply before filling air line lubricator.

The Inlet Strainer (42 or 344) must be installed on the hoist. Failure to do so may result in a hoist malfunction.

The Bleed Adjustment Screws (35 or 336) used on hoists with a pendent control are factory adjusted to provide optimum control at 90 psig (6.2 bar/620 kPa) air pressure. If the hoist is used with other air supply pressures, the Bleed Adjustment Screws may require readjustment.

### Adjustment of Bleed Screws on Pendent Control Models

For maximum performance and control, adjust the bleed screws (35 or 336) as follows:

1. Loosen the Adjustment Screw Locknut (36 or 337).
2. Back out the Adjustment Screw (35 or 336) approximately one third (1/3) of a turn.
3. While fully depressing the Pendent Throttle Lever (205) and holding it in that position, turn in the Adjustment Screw until the Piston Rod fully retracts. This adjustment will provide a good balance of spotting control and maximum hoist speed. If better spotting control is desired, slowly back out the Adjustment Screw a little at a time until the spotting control is suitable.
4. Tighten the Adjustment Screw Locknut (36 or 337).

### Storing the Hoist

1. Always store the hoist in a no load condition.
2. Wipe off all dirt and water.
3. Oil the load chain, hook pins and hook latch.
4. Place in a dry location.
5. Plug hoist air inlet port.
6. Before returning hoist to service follow instructions for Hoists not in Regular Service in the "INSPECTION" section.



## OPERATION

The four most important aspects of hoist operation are:

1. Follow all safety instructions when operating hoist.
2. Allow only people trained in safety and operation on this product to operate hoist.
3. Subject each hoist to a regular inspection and maintenance as outlined in ASME B30.16.
4. Be aware of the hoist capacity and weight of load at all times.

Operators must be physically competent. Operators must have no health condition which might affect their ability to act, and they must have good hearing, vision and depth perception. The hoist operator must be carefully instructed in his duties and must understand the operation of the hoist, including a study of the manufacturer's literature. The operator must thoroughly understand proper methods of hitching loads and should have a good attitude regarding safety. It is the operator's responsibility to refuse to operate the hoist under unsafe conditions.

### Initial Operating Checks

Hoists are tested for proper operation prior to leaving the factory. Before the hoist is placed into service the following initial operating checks should be performed.

1. After installation of trolley mounted hoists, check to ensure the hoist is centered below the trolley.
2. Check for air leaks in the supply hose and fittings to pendant, and from pendant to manifold.
3. When first running the hoist or trolley motors some light oil should be injected into the inlet connection to allow good lubrication.
4. When first operating the hoist and trolley it is recommended that the motors be driven slowly in both directions for a few minutes.
5. Operate the trolley along the entire length of the beam.
6. Inspect hoist and trolley performance when raising, moving and lowering test load(s). Hoist and trolley must operate smoothly and at rated specifications prior to being placed in service.
7. Check that trolley (if equipped) and hook movement is the same direction as arrows or information on the pendant control.
8. Raise and lower a light load to check operation of the hoist brake.
9. Check hoist operation by raising and lowering a load equal to the rated capacity of the hoist a few inches (cm) off the floor.
10. Check operation of limit devices.
11. Check to see that the hoist is directly over the load. Do not lift the load at an angle (side pull or "yard").

12. Check to see that the hoist is securely connected to the overhead crane, monorail, trolley or supporting member.
13. Check to see that the load is securely inserted in the hook, and that the hook latch is engaged.

### **⚠ WARNING**

- Only allow personnel trained in safety and operation of this product to operate the hoist and trolley.
- The hoist is not designed or suitable for lifting, lowering or moving persons. Never lift loads over people.

### Hoist Controls

#### MLK Two Lever Pendant

Two lever pendants provide operation of the hoist only. For units with powered trolleys a four lever pendant is required.

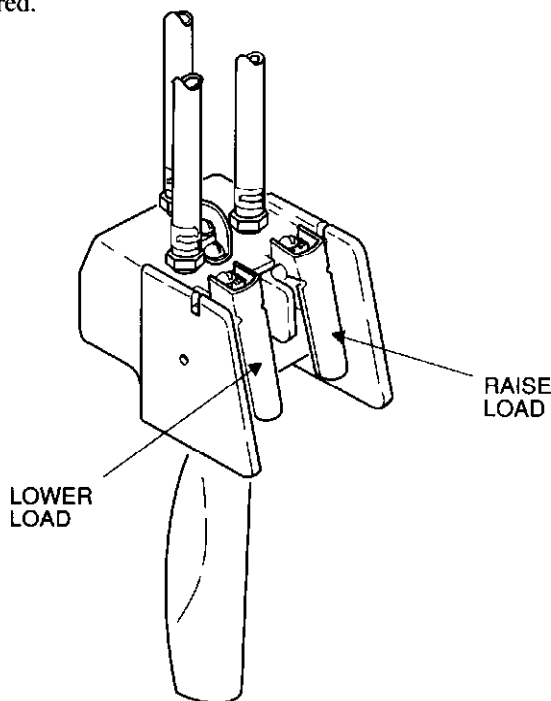

(Dwg. MHTPA0427)

### **⚠ WARNING**

- The hook latch is intended to retain loose slings or devices under slack conditions. Hook latches are not intended to be an anti-fouling device, so caution must be used to prevent the latch from supporting any of the load.

Refer to Form P6778 for information on Pendant Throttle Handle Assemblies for two and three motor functions.

# INSPECTION

There are two types of inspection, the frequent inspection performed by the operator and periodic inspections performed by personnel trained in the operation and repair of this hoist.

Careful inspection on a regular basis will reveal potentially dangerous conditions while still in the early stages, allowing corrective actions to be taken before the condition becomes dangerous.

Any deficiency revealed through inspection must be reported to an appointed person. A determination must be made as to whether a deficiency constitutes a safety hazard before resuming operation of the hoist.

## Records and Reports

Some form of inspection record should be maintained for each hoist, listing all points requiring periodic inspection. A written report should be made monthly on the condition of the critical parts of each hoist. These reports should be dated, signed by each person who performed the inspection, and kept on file where they are readily available to authorized personnel.

## Frequent Inspection

On hoists in continuous service, frequent inspection should be made at the beginning of each shift. In addition, visual inspections should be conducted during regular service for any damage or evidence of malfunction.

1. **OPERATION.** Check for visual signs or abnormal noises (grinding etc.) which could indicate a potential problem. Make sure all controls function properly and return to neutral when released. Check chain feed through the hoist and bottom block. If chain binds, jumps, is excessively noisy or "clicks", clean and lubricate the chain. If problem persists, replace the chain. Do not operate the hoist until all problems have been corrected.
2. **HOOKS.** Check for wear or damage, increased throat width, bent shank or twisting of hook. Replace hooks which exceed the throat opening discard width specified in Table 2 (see Dwg. MHTPA0040) or exceed a 10° twist (see Dwg. MHTPA0111). If the hook latch snaps past the tip of the hook, the hook is sprung and must be replaced. Refer to the latest edition of ASME B30.10 "HOOKS" for additional information. Check hook support bearings for lubrication or damage. Ensure they swivel easily and smoothly.

3. **UPPER AND LOWER LIMIT DEVICE.** Test operation with no load slowly to both extremes of travel. Upward travel must stop when the bottom block or stop buffer on chain hits hoist limit arm. Downward travel must stop when the loop at the unloaded end of the chain decreases and activates the limit arm.

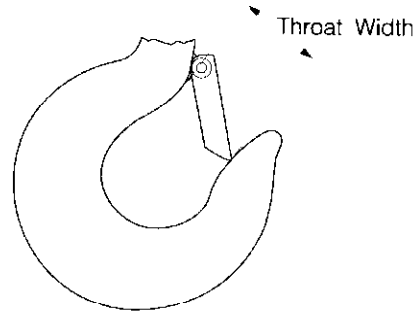

(Dwg. MHTPA0040)

**Table 2**

Hoist Model	Throat Opening			
	New Hook		Discard Hook	
	in.	mm	in.	mm
ML250K, ML250KS, ML500K and ML500KS	1-1/16	27.0	1-5/32	29.0
ML1000K and ML1000KS	1-1/4	31.8	1-7/32	31.0
ML250KR and ML500KR	1-7/32	31.0	1-5/16	33.4

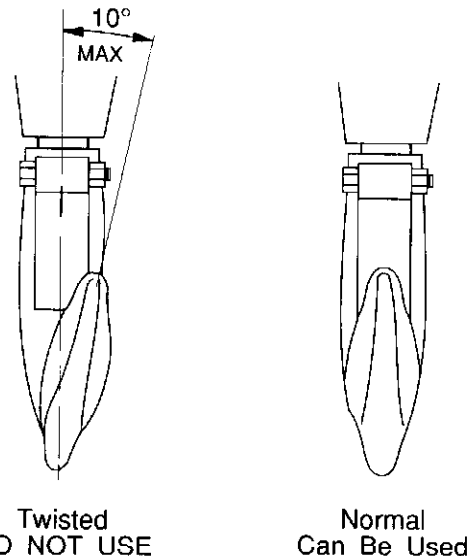

(Dwg. MHTPA0111)

4. **AIR SYSTEM.** Visually inspect all connections, fittings, hoses and components for indication of air leaks. Repair any leaks found. Check and clean the filter in the Inlet Nipple, if equipped, and the strainer in the Inlet Strainer (42).

5. **CONTROLS.** During operation of hoist, verify response to pendant is quick and smooth. See that the controls return to neutral when released. If hoist responds slowly or movement is unsatisfactory, do not operate hoist until all deficiencies have been corrected.
6. **HOOK LATCH.** Make sure the hook latch is present and operating. Replace if necessary.

**⚠ CAUTION**

• **Do not use hoist if hook latch is missing or damaged.**

7. **LOAD CHAIN.** Examine each of the links for bending, cracks in weld areas or shoulders, traverse nicks and gouges, weld splatter, corrosion pits, striation (minute parallel lines) and chain wear, including bearing surfaces between chain links (see Dwg. MHTPA0102). Replace a chain that fails any of the inspections. Check chain lubrication and lubricate if necessary. Refer to "Load Chain" in "LUBRICATION" section.

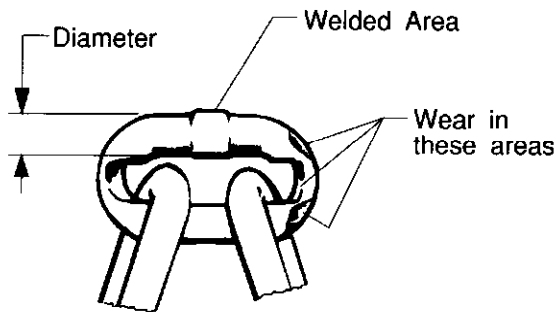

(Dwg. MHTPA0102)

**NOTICE**

• **The full extent of load chain wear cannot be determined by visual inspection. At any indication of load chain wear inspect chain and chain wheel in accordance with instructions in "Periodic Inspection".**

8. **LOAD CHAIN REEVING.** Ensure welds on standing links are away from the powered chain wheel. Reinstall chain if necessary. Make sure chain is not capsized, twisted or kinked. Adjust as required.

**Periodic Inspection**

According to ASME B30.16, frequency of periodic inspection depends on the severity of usage:

<b>NORMAL</b>	<b>HEAVY</b>	<b>SEVERE</b>
yearly	semi-annually	quarterly

Disassembly may be required for HEAVY or SEVERE usage. Keep accumulative written records of periodic inspections to provide a basis for continuing evaluation. Inspect all the items in "Frequent Inspection". Also inspect the following:

1. **FASTENERS.** Check all rivets, split pins, capscrews and nuts. Replace if missing or tighten if loose.
2. **ALL COMPONENTS.** Inspect for wear, damage, distortion, deformation and cleanliness. If external evidence indicates the need, disassemble. Check gears, shafts, bearings, sheaves, chain guides, springs and covers. Replace worn or damaged parts. Clean, lubricate and reassemble.
3. **HOOKS.** Inspect hooks carefully for cracks using magnetic particle or other suitable non-destructive method. Inspect hook retaining parts. Tighten or repair, if necessary.
4. **LOAD CHAIN WHEELS.** Check for damage or excessive wear. Replace if necessary. Observe the action of the load chain feeding through the hoist. Do not operate a hoist unless the load chain feeds through the hoist and hook block smoothly and without audible clicking or other evidence of binding or malfunctioning.
5. **MOTOR.** If performance is poor, disassemble the motor and check for wear or damage to bearings and shafts. The parts should be cleaned, lubricated and reassembled. Replace worn or damaged parts.
6. **BRAKE.** Raise a load equal to the rated capacity of the hoist a few inches (cms) off the floor. Verify hoist holds the load without drift. If drift occurs, disassemble. Remove brake discs as described in the "MAINTENANCE" section. Check and clean the brake parts each time the hoist is disassembled. Replace the brake discs if the thickness is less than .090 in. (2.29 mm).
7. **SUPPORTING STRUCTURE.** Check for distortion, wear and continued ability to support load.
8. **TROLLEY.** (if equipped) Check that the trolley wheels track the beam properly and clearance between side rollers and beam is correct, 1/16 to 3/16 in. (1.6 to 4.7 mm). Check and that wheels and rail are not excessively worn and inspect side plates for spreading due to bending. Do not operate the hoist until the problem has been determined and corrected.
9. **LABELS AND TAGS.** Check for presence and legibility. Replace if necessary.
10. **LOAD CHAIN END ANCHORS.** Ensure both ends of load chain are securely attached. Secure if loose, repair if damaged, replace if missing. Check chain stopper is correctly installed and functional.
11. **LOAD CHAIN.** Measure the chain for stretching by suspending a 50 to 100 lbs. (23 to 45 kg) load from the hoist. Measure the load chain over the outside of seven link sections all along the chain paying particular attention to the most frequently reeved links. When any seven links in the working length reaches or exceeds the discard length shown in Table 3, replace the entire chain (see Dwg. MHTPA0041). Always use a genuine **INGERSOLL-RAND Material Handling** replacement chain.

**Table 3**

Dimensions Of Link - Inches				'N' Number Of Links	Discard Length Over N Links, Inches
Nominal Wire Dia.	Pitch	Inside Width	Outside Width		
1/4	0.767	0.298	0.823	7	5.89

Zinc plated load chain is available for standard hoists.  
Always use stainless steel load chain on Spark Resistant  
Hoists.

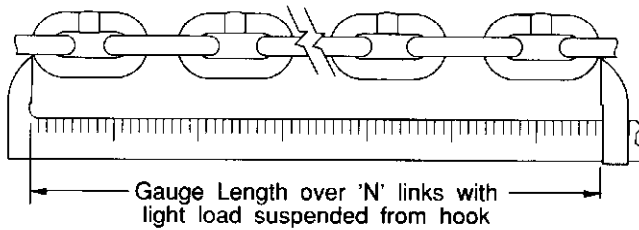

(Dwg. MHTPA0455)

12. CHAIN CONTAINER. Check for damage or excessive wear and that chain container is securely attached to the hoist. Secure or replace if necessary.
13. LIMIT ASSEMBLY. Check limit arm moves freely.

**Hoists Not in Regular Use**

1. A hoist which has been idle for a period of one month or more, but less than one year, should be given an inspection conforming with the requirements of "Frequent Inspection" prior to being placed into service.
2. A hoist which has been idle for a period of more than one year should be given an inspection conforming with the requirements of "Periodic Inspection" prior to being placed into service.
3. Standby hoists should be inspected at least semi-annually in accordance with the requirements of "Frequent Inspection". In abnormal operating conditions hoists should be inspected at shorter intervals.

To ensure continued satisfactory operation of the hoist, all points requiring lubrication must be serviced with the correct lubricant at the proper time interval as indicated for each assembly. Correct lubrication is one of the most important factors in maintaining efficient operation.

The lubrication intervals recommended in this manual are based on intermittent operation of the hoist eight hours each day, five days per week. If the hoist is operated almost continuously or more than the eight hours each day, more frequent lubrication will be required. Also, the lubricant types and change intervals are based on operation in an environment relatively free of dust, moisture, and corrosive fumes. Use only those lubricants recommended. Other lubricants may affect the performance of the hoist. Approval for the use of other lubricants must be obtained from your **Ingersoll-Rand** Technical Support Department or distributor. Failure to observe this precaution may result in damage to the hoist and/or its associated components.

Whenever a Series MLK Hoist is disassembled for overhaul or replacement of parts, lubricate as follows:

1. Coat all motor parts with a light film of **Ingersoll-Rand Pneu-Lube® Medium Oil No. 50** or a good quality hydraulic oil before assembling.

## CAUTION

• **Do not use automotive type detergent oil. Detergents will delaminate the motor vanes and cause premature failure.**

2. Apply a coating of **Ingersoll-Rand No. 11 Grease** to the Planet Gear Bearings (83), the Brake Driver Bearing (87), and gearing before assembly.
3. The top and bottom hooks are supported by thrust bearings. These bearings must be packed with **Ingersoll-Rand No. 68 grease** or a standard No. 2 multi-purpose grease at regular intervals. Neglect of proper lubrication will lead to bearing failure.

## Load Chain

### WARNING

• **Failure to maintain clean and well lubricated load chain will result in rapid load chain wear that can lead to chain failure which can cause severe injury, death or substantial property damage.**

1. Lubricate load chain weekly, or more frequently, depending on severity of service.
2. In a corrosive environment, lubricate more frequently than normal.
3. Lubricate each link of the load chain and apply new lubricant over existing layer.
4. Lubricate hook and hook latch pivot points.
5. If required, clean chain with acid free solvent to remove rust or abrasive dust build-up and lubricate the chain.
6. Use **Ingersoll-Rand LUBRI-LINK®** or a SAE 50 to 90 EP oil.

## Hook Assemblies

1. Lubricate the hook and hook latch pivot points. Hook and latch should swivel/pivot freely.
2. Use **Ingersoll-Rand LUBRI-LINK®** or a SAE 50 to 90 EP oil.

## Trolley (if equipped)

Periodically, grease the wheel bearings with **Ingersoll-Rand No. 68 grease** or a standard No.2 multi-purpose grease. A grease fitting is provided on the end of each wheel axle.

## TROUBLESHOOTING

This section provides the information necessary for troubleshooting this hoist. The troubleshooting guide provides a general outline of problems which could be experienced with normal use of this hoist. It lists the symptom, the possible cause, and the possible remedy for the trouble being experienced.

SYMPTOM	CAUSE	REMEDY
Hoist will not operate.	No air supply to hoist, or too little CFM or PSI.  Valve or throttle lever sticking.  Pendant malfunction.  Hoist is overloaded.  Motor is damaged.  Lubricator is low on oil.  Brake is not releasing.	Check PSI (bar) at valve inlet. Refer to "SPECIFICATIONS" section for correct CFM (cu.m/min) and PSI (bar).  Check throttle lever for free movement.  Check PSI (bar) at pendant. Minimum operating pressure in pendant line is 55 PSI (3.8 bar).  Reduce load to within rated capacity.  Repair or replace. See "MAINTENANCE" section.  Fill lubricator.  Check brake release circuit and PSI (bar) at the brake inlet. (55 PSI (3.8 bar) minimum)
Load continues to move when hoist is stopped. "UP" direction.	Valve or throttle lever sticking.  Dump valves not releasing.  Pendant lever sticking.	Check throttle lever for free movement.  Check pendant hose dump valves.  Check lever and restore free movement.
Load continues to move when hoist is stopped. "DOWN" direction.	Valve or throttle lever sticking.  Dump valves not releasing.  Brake is slipping.  Hoist is overloaded.  Pendant lever sticking.	Check throttle lever for free movement.  Check pendant hose dump valves.  Check brake springs and brake disc linings for wear. See "MAINTENANCE" section.  Reduce load to within rated capacity.  Check lever and restore free movement.
Hoist will not lift rated capacity.	Hoist is overloaded.  No air supply to hoist, or too little CFM or PSI.  Main air valve travel is restricted.  Exhaust restricted.  Motor is damaged.	Reduce load to within rated capacity.  Check PSI (bar) at valve inlet. Refer to "SPECIFICATIONS" section for correct CFM (cu.m/min) and PSI (bar).  Check throttle lever and linkage for free movement.  Inspect vents and replace mufflers.  Check for worn motor bearings, vanes or vane springs.
Reduced speed and/or capacity.	Old style hoists have filter in inlet nipple which may be plugged restricting air flow.	Install new style inlet nipple with no filter screen.

<b>SYMPTOM</b>	<b>CAUSE</b>	<b>REMEDY</b>
Hook lowers, but will not raise.	No air supply to hoist, or too little CFM (cu.m/min). Hoist is overloaded. Pendant malfunction.	Check power supply and connections, in power supply line. Reduce load to within rated capacity. Check PSI (bar) at air inlet connection on pendant.
Hook can be raised but not lowered.	Brake piston seals leaking. Low air pressure. Pendant malfunction.	Install new seals refer to "MAINTENANCE" section. Check PSI (bar) at valve inlet. Raise pressure to rated capacity. Check PSI (bar) at fitting connection on pendant.
Load chain jumps on sheave or is making a snapping sound.	No oil on load chain. Worn or rusted chain. Worn load sheave. Capsized Hook. Hoist not in-line with load. Incorrectly reeved load chain.	Lubricate load chain. See "LUBRICATION" section. See "INSPECTION" to determine wear limit. Replace if necessary and lubricate frequently. Replace worn parts. Correct as described in "MAINTENANCE" section. Align hoist with load. Do not "yard" or side pull. Check load chain is correctly reeved.
<b>Trolley</b> Trolley won't stop or trolley wheels slip.	Damaged beam. Too much oil, grease or paint on track of beam. Trolley not spaced for beam clearance.	Repair or replace beam. Clean off oil, grease or paint. Check trolley spacing. Refer to "INSTALLATION" section.
Air powered trolley does not operate.	Pendant lever sticking. No air supply to trolley, or too little CFM (cu.m/min) or PSI (bar). Control valve is sticking.	Check lever and restore free movement. Check PSI (bar) at trolley valve. See "MAINTENANCE" section.

**⚠ WARNING**

- Never perform maintenance on the hoist while it is supporting a load.
- Before performing maintenance, tag controls:  
**DANGER - DO NOT OPERATE - EQUIPMENT BEING REPAIRED.**
- Only allow personnel trained in the operation and service of this hoist to perform maintenance.
- After performing any maintenance on the hoist, dynamically test hoist to 100% of its rated capacity, in accordance with ASME B30.16 standards, before returning hoist to service. Testing to more than 100% of rated capacity may be required to comply with standards and regulations set forth in areas outside of the USA.
- Shut off air system and depressurize air lines before performing any maintenance.

**Load Chain Care**

Keep the chain well lubricated as instructed in the "LUBRICATION" section. Never operate a hoist when the load chain does not flow freely and smoothly into and out of the Chain Wheel, or when it makes noises indicative of binding or other malfunctions.

**Chain Replacement**

Refer to "INSPECTION" section for information on load chain inspection. Excessive chain wear cannot be detected by casual observation. The chain is case hardened to a depth of 0.010 in. to 0.012 in. (25 to 30 mm) and once this case is worn through, wear will progress rapidly and the strength of the chain will be considerably reduced. Further, the chain will no longer fit the Chain Wheel properly, greatly increasing the chance of malfunction and chain breakage. One Chain Wheel will outlast several chains if the chain is replaced as recommended. The use of a worn chain will cause the Chain Wheel to wear rapidly.

If the chain is visibly damaged, examine the Chain Wheel and Chain Guard. Install a new Chain Wheel if the old one is visibly worn. Install a new Guard if the old one is broken or distorted.

**For Single Line (fall) Hoists, Method 1**

1. Remove the Brake Spring and Piston Housing, Brake Discs and Brake Plates to expose the Brake Driver.
2. At the side of the Chain Wheel opposite the Chain Anchor Bolt, engage the first link of Chain in a pocket of the Chain Wheel FLAT SIDE DOWN (Dwg. TPD571-1). The weld on the second link must face away from the powered Chain Wheel. (Ref. Dwg. MHTPA0472).

3. Rotate the Brake Driver by hand to thread the Chain through the hoist.
4. Keep the Chain straight and do not twist it. Attach the free end of the Chain using the Chain Anchor Bolt, Washers and Spacer (Dwg. TPD572). Clean the brake parts and inspect them for excessive wear before assembling.

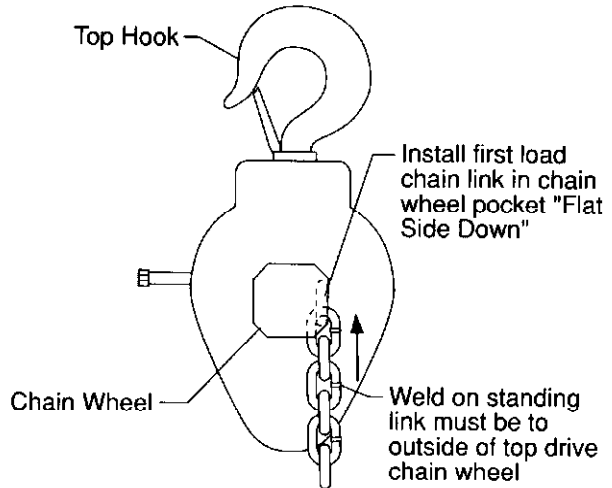

(Dwg. TPD571-1)

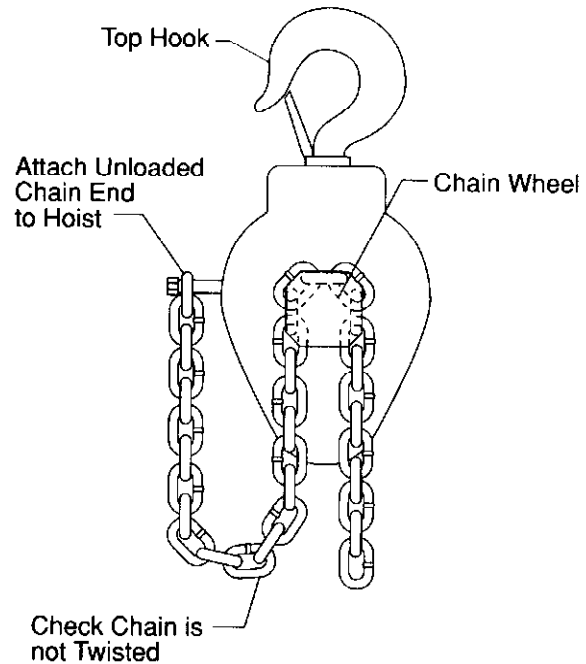

(Dwg. TPD572)



## For Double Line Hoists, Method 1

### **⚠ WARNING**

• The replacement chain for a series MLK double line hoist must have an **EVEN** number of links.

1. Install the Chain through the Chain Wheel as in Steps 1 through 4 of the instructions for single line Hoist, and attach the end of the Chain to the Hoist using the Anchor Bolt and fasteners. Keep the Chain straight.
2. Make certain the Chain is straight and feed the end through the bottom hook pocket wheel with the first link **ON EDGE WITH THE WELD TO THE INSIDE OF THE IDLER SHEAVE WHEEL.**
3. Keep the Chain straight and attach the free end to the chain anchor bracket.

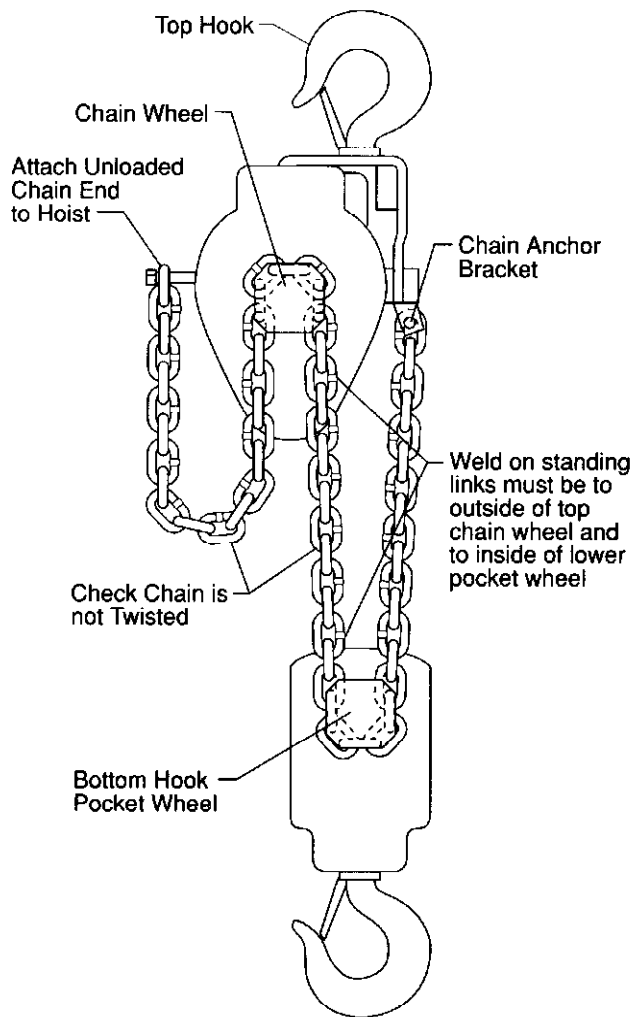

(Dwg. TPD574)

## Capsized Hook

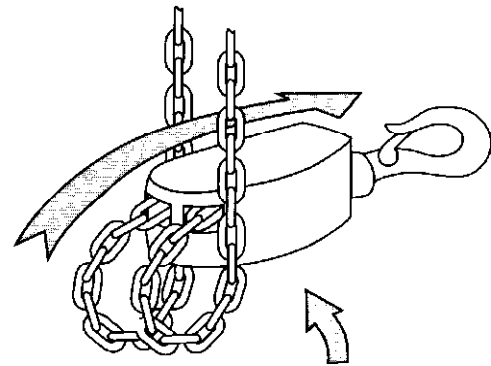

Make certain the bottom block has **NOT** been flipped through the chain falls

(Dwg. MHTPA0043)

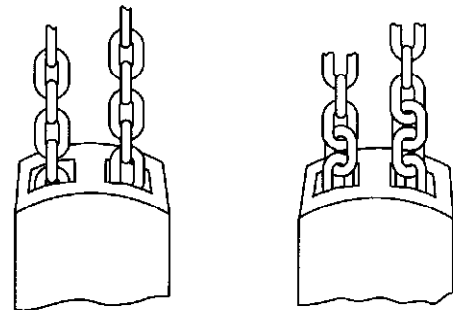

Appearance of chain that is **Not Twisted**

Appearance of chain that **Is Twisted**

(Dwg. MHTPA0020)

## For Single or Double Line Hoists, Method 2

1. On ML250K and ML500K single line Hoists, disconnect the load end of the Chain from the Bottom Hook Block. On ML500KR and ML1000K double line Hoists, disconnect the load end of the Chain from the Chain Anchor Bracket and withdraw it from the Bottom Hook Sheave Block. Do not remove the Chain from the Hoist.
2. Using an abrasive wheel, cut a section from the last standing link as shown in Dwg. MHTPA0471.

### **⚠ CAUTION**

• Do not distort the link in any manner. It must be able to pass over the Chain Wheel without binding. The last complete link of old chain must be a flat link unless two cut links are used to make the first link of the new chain a flat link.

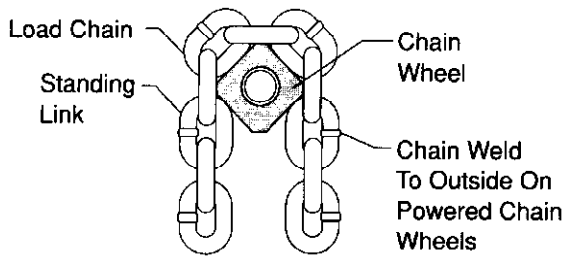

(Dwg. MHTPA0472)

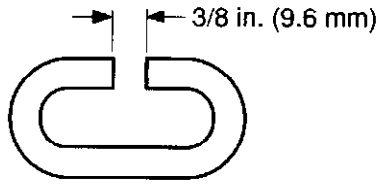

"C" Link

(Dwg. MHTPA0471)

3. Connect old Chain by hooking the end of the new Chain onto the cutaway link. Make certain the welds on the standing links (links that are perpendicular to the Chain Wheel) face away from the powered Chain Wheel.
4. Slowly run the Hoist in the raise direction, running off the old Chain and reeving the new Chain over the Chain Wheel. The first link of new Chain over the Chain Wheel must be a flat link.
5. After the new Chain is installed, secure the unloaded end of the Chain to the side of the Hoist. Make certain there is no twist in the unloaded end of the Chain between the Chain Wheel and the end link.

### ⚠ WARNING

• A twisted Chain can jam as it passes over the Chain Wheel, which can result in damage to the Hoist or even breaking the Chain causing severe injury, death or substantial property damage.

6. On single line Hoists, install the Stop Ring (115) and Spring (114) and then attach the Bottom Hook Block Assembly.
7. On double line Hoists, reeve the load end of the new Chain around the Pocket Wheel in the Sheave Block Assembly, making certain the Chain is not twisted between the Hoist and Sheave Block.

### NOTICE

• The new chain must have an EVEN number of links when the hoist has two chain falls and uses a bottom sheave block.

8. Keeping the load end of the Chain straight, attach the end link to the Chain Anchor Bracket.

9. Lubricate the Chain as instructed in the "LUBRICATION" section.
10. Run the hook up and down several times under power with no load to make certain the Chain is running smoothly over the Chain Wheel. There must be no apparent binding or evidence of malfunctioning.

### Servicing the Filter and Strainer

1. Disconnect the air supply from the Hoist.
2. Unscrew the air hose from the Inlet Strainer (42) or (344 old style).
3. Unscrew the Inlet Strainer from the Inlet Body (38 or 340).
4. Wash the screen inside the Inlet Strainer clean with a quality, non-toxic, nonflammable commercial solvent in a well ventilated area. If the screen is damaged or cannot be cleaned, replace the Inlet Strainer.
5. Unscrew the Inlet Nipple (39 or 341) from the Valve Chest and remove the Inlet Nipple and Inlet Body from the Valve Chest.
6. Push the Inlet Nipple out of the Inlet Body.
7. Remove the two Swivel Inlet Seals (40 or 342) from the Inlet Nipple.
8. If the Swivel Inlet Gasket (41 or 343) is damaged, replace it.
9. If hoist is equipped with a filter inside the Inlet Nipple, clean by washing with a quality, non-toxic, nonflammable commercial solvent in a well ventilated area. If the filter cannot be cleaned, replace the Inlet Nipple. (New style Inlet Nipples do not have filters)
10. Moisten the new Swivel Inlet Seals with O-ring lubricant and install them in the grooves around the body of the Inlet Nipple.
11. Push the Inlet Nipple into the Inlet Body until the hex of the Nipple is flush against the face of the Inlet Body.
12. Keep the threaded hole of the Inlet Body facing away from the Hoist and screw the Inlet Nipple into the Valve Chest.
13. Screw the Inlet Strainer into the Inlet Body.
14. Screw the air hose into the Inlet Strainer.
15. Reconnect the air supply to the Hoist.

### Disassembly

### ⚠ WARNING

• Disconnect the air supply hose before performing any maintenance or repairs on this Hoist.

### General Instructions

1. The MLK Hoist is constructed of various modules, and during the process of disassembly it is not always necessary to disassemble a particular module just because it is removed from the Hoist. For example, it is necessary to remove the Valve Chest Assembly in order to disassemble the motor. However, the Valve

Chest need not be disassembled unless parts within the Valve Chest require replacement. Do not disassemble the Hoist any further than necessary to replace or repair damaged parts.

2. Whenever grasping a part in a vise, always use leather-covered or copper-covered vise jaws to protect the surface of the part and help prevent distortion. This is particularly true of threaded members and housings.
3. Do not remove any part which is a press fit in or on a sub-assembly unless the removal of that part is necessary to complete the repair or replacement of the part.
4. Do not disassemble this Hoist unless you have a complete set of new gaskets, O-rings and seals on hand for replacement. These are available in Overhaul Gasket Kit MLK-K445.
5. Do not attempt to wash sealed bearings.

### **Disassembly of the Valve Chest used on Hoists with second letter of the Serial Number other than A through G or with second and third letters of the Serial Number other than HA, HB or HC.**

1. If the Hoist has a pendent control, disconnect the three Pendent Hoses (211) from the Elbow and Adapters (221 and 222).
2. Remove the Pendent Links (223).
3. Unscrew the Valve Chest Screws (44 and 45) and remove the Valve Chest (14) and Valve Chest Gaskets (43).
4. Unscrew and remove the Swivel Inlet Assembly. Push the Inlet Nipple (39) out of the Inlet Body (38) to expose the Swivel Inlet Seals (40).
5. Unscrew the Valve Chest Cover Screws (37) and remove the Valve Chest Cover (33) and Valve Chest Cover Gasket (31).
6. Remove the Piston and Piston Shaft Assemblies (26 and 28) and Piston Springs (25).
7. Remove the Valve Seat Lock Screws (23).
8. While exerting pressure against the Valve Seats (20), use retaining ring pliers to remove the Valve Seat Retainers (24).
9. Using a hooked tool, pull the Valve Seats from the Valve Chest or tap the bottom of the Valve Chest on a block of wood.
10. Remove the two Valve Assemblies (15 and 17) and Valve Springs (19) from the Valve Chest.
11. If the Piston Shaft Seals (29) require replacement, press the Piston Retaining Pins (30) from each Piston and Shaft and slide the Pistons off the Shafts.

### **Disassembly of the Valve Chest used on Hoists with second letter of the Serial Number A through G or with second and third letters of the Serial Number HA, HB, or HC.**

#### **NOTICE**

• **Parts for this style valve chest may no longer be available. To replace with current style valve chest order kit no. MLK-K545B (03835519).**

1. If the hoist has a pendent control, disconnect the three Pendent Hoses (211) at the Elbows (221 and 222).
2. Unscrew the Valve Chest Screws (44 and 45) and remove the assembled Valve and Valve Chest Gaskets (43).
3. Unscrew and remove the Swivel Inlet Assembly (340). Slide the inlet sleeve off the swivel body to expose the Swivel Inlet Seals (342).
4. Unscrew the Valve Chest Cover Capscrews (339), and remove the Valve Chest Cover (334) along with the Piston Rods (328 and 329), Pistons (330) and Piston Springs (333). Remove the Valve Chest Cover Gasket (338).
5. Withdraw the two Valves (325) and the two Valve Springs (327).

#### **NOTICE**

• **Do not mix the Valves (325). They are a lap fit in their respective sleeve.**

### **Disassembly of the Brake Mechanism**

1. Unscrew the four Shoulder Bolts (105) and remove the assembled Spring and Piston Housing (96).
2. If you are going to disassemble the Spring and Piston Housing, proceed as follows:
  - a. Remove the Plate Screws (104) and the Plate (103).
  - b. Place the assembly, Pressure Plate (98) downward, on an arbor press or place the assembly vertically in a vise.
  - c. While holding the Housing against the compression of the Springs (97), hold the Pressure Plate Screw (98A) with a wrench and unscrew the Piston Nut (98B).
  - d. Ease up on the arbor press slowly and carefully.
  - e. Pull off the Pressure Plate and push the Piston (99) from the Housing.
3. Withdraw the Brake Plates (94) and Brake Discs (95).

### **Disassembly of the Motor**

1. Remove the entire brake mechanism. Refer to Disassembly of the Brake Mechanism.
2. Remove the Brake Driver Retainer (93) and withdraw the Brake Driver (92).

3. Remove the assembled Valve Chest (14). Refer to Disassembly of the Valve Chest.
4. Remove the Limit Actuator Retaining Pin (52) and withdraw the Limit Actuator (51).
5. Unscrew the Valve Chest Plate Screws (48) and remove the Valve Chest Plate (46).
6. Grasp the Rear End Plate (67) and pull the entire assembled motor from the Hoist. If the motor is a little “sticky”, tap on the brake end of the Motor Shaft (64) with a soft drift.

## NOTICE

• **If the Cylinder Dowel (71) separates from the assembled motor, insert a long pin in the dowel pin hole to align the Front End Plate (72) during removal.**

7. Grasp the Motor Shaft vertically in copper-covered vise jaws.
8. Remove the Motor Shaft Rear Retaining Ring (65).
9. Lift off the Rear End Plate (67) and Bearing (66), Cylinder (70), Cylinder Dowel (71), Vanes (69), Rotor (68), Front End Plate (72) and Bearing (73).

### Disassembly of the Gearing

1. Remove the entire brake mechanism. Refer to Disassembly of the Brake Mechanism.
2. Remove the Brake Driver Retainer (93) and withdraw the Brake Driver (92).
3. Withdraw the Brake Tube (57).
4. Grasp the Brake Housing (90) and pull it away from the Housing (1) just far enough to expose the two cutout areas at the rear of the Housing. Rotate the Brake Housing until the large diameter of each Planet Gear (82) is aligned with a cutout area. Withdraw the Brake Housing, Ring Gear (88) and Planet Gear Frame Assembly as a unit.
5. Remove the Ring Gear Gasket (89).
6. Pull the Brake Housing (90) from the Gear Frame Bearing (86). If it is a little “sticky”, lightly tap on the rear of the Planet Gear Frame (81) with a plastic hammer to loosen it.
7. Pull the Ring Gear (88) from the Brake Housing, if required.
8. Using a bearing puller, remove the Gear Frame Bearing (86).
9. Remove the Planet Gear Shafts (85) by pressing them toward the short hub end of the Planet Gear Frame (81).
10. Do not remove the needle bearings (83 or 87) from the Planet Gears (82) or Planet Gear Frame unless you have new bearings on hand for installation. A needle bearing is always damaged during the removal process.

### Disassembly of the Throttle Lever and Chain Guide

1. Drive out the Limit Actuator Retaining Pin (52) and remove the Limit Actuator (51).

2. Drive out the Throttle Lever Retaining Pin (54).
3. Grasp the square end of the Throttle Shaft (50) and withdraw it from the Hoist.
4. Unscrew the Chain Guide Screws (11) and remove the Chain Guide (10).

### Disassembly of the Chain Wheel and Chain Guard

1. Remove the brake mechanism. Refer to Disassembly of the Brake Mechanism.
2. Remove the Valve Chest. Refer to Disassembly of the Valve Chest.
3. Remove the Motor. Refer to Disassembly of the Motor.
4. Remove the Gearing. Refer to Disassembly of the Gearing.
5. Remove the Throttle Lever and Chain Guide. Refer to Disassembly of the Throttle Lever and Chain Guide.
6. Using a soft drift, lightly tap the motor end of the Chain Wheel (76) to drive it out through the brake end of the Housing.
7. Use a bearing puller to remove the Chain Wheel Bearings (77 and 79).
8. Remove the Chain Guard Retaining Screws (13A) and remove the Chain Guard (13).

## Cleaning, Inspection and Repair

Use the following procedures to clean, inspect, and repair the components of the hoist.

### Cleaning

## ⚠ CAUTION

- **Bearings that are loose, worn or rotate in the housing must be replaced. Failure to observe this precaution will result in additional component damage.**
- **Do not use trichloroethylene to clean parts.**

Clean all hoist component parts in solvent (except for the brake discs). The use of a stiff bristle brush will facilitate the removal of accumulated dirt and sediments on the gears and frames. If bushings have been removed it may be necessary to carefully scrape old Loctite® from the bearing bores. Dry each part using low pressure, filtered compressed air.

### Inspection

All disassembled parts should be inspected to determine their fitness for continued use. Pay particular attention to the following:

1. Inspect all gears for worn, cracked, or broken teeth.
2. Inspect all bushings for wear, scoring, or galling.
3. Inspect shafts for ridges caused by wear. If ridges caused by wear are apparent on shafts, replace the shaft.
4. Inspect all threaded items and replace those having damaged threads.

5. Measure the thickness of the brake discs (95). If the brake discs are less than 0.090 in. (2.29 mm) replace the brake discs (95).
6. Check mufflers (49) for damage or excessive dirt.
7. Check bearings for freeness of rotation and wear. Replace bearings if rotation is rough or bearings are excessively worn.
8. Inspect brake driver bearing wear area on brake driver (92) and in planet gear frame (81) for ridges or galling. If either condition exists replace parts.

### Repair

Actual repairs are limited to the removal of small burrs and other minor surface imperfections from gears and shafts. Use a fine stone or emery cloth for this work.

1. Worn or damaged parts must be replaced. Refer to the applicable parts listing for specific replacement parts information.
2. Inspect all remaining parts for evidence of damage. Replace or repair any part which is in questionable condition. The cost of the part is often minor in comparison with the cost of redoing the job.
3. Smooth out minor nicks, burrs, or galled spots on shafts, bores, pins, or bushings.
4. Examine all gear teeth carefully, and remove nicks or burrs.
5. Polish the edges of all shaft shoulders to remove small nicks which may have been caused during handling.
6. Remove all nicks and burrs caused by lockwashers.
7. Replace all seals, 'O' rings and gaskets.

### Assembly

#### General Instructions

1. The MLK Hoist is constructed of various modules. The following instructions will first describe how to assemble the individual modules and finally, how to assemble a complete hoist from the assembled modules.
2. Always press on the inner ring of a ball-type bearing when installing the bearing on a shaft.
3. Always press on the outer ring of a ball-type bearing when pressing the bearing in a bearing recess.
4. Always press against the stamped end of a needle-type bearing when installing the bearing in a bearing recess.
5. Whenever grasping a part in a vise, always use leather-covered or copper-covered vise jaws to protect the surface of the part and help prevent distortion. This is particularly true of threaded members and housings.
6. Always clean and wipe every part (except the brake parts) with a thin film of oil before installation.
7. Never wash sealed bearings in solvent or any other cleaner.

#### Assembly of the Chain Wheel and Chain Guard

1. Place the Chain Guard (13) in position, and install the two Chain Guard Screws (13A) and Lockwashers (13B).

2. Place the Chain Wheel Plain End Washer (78) on the plain or short hub of the Chain Wheel (76).
3. Press the Chain Wheel Plain End Bearing (77) on the plain or short hub of the Chain Wheel until it contacts the Chain Wheel Plain End Washer.
4. Slide the Chain Wheel Splined End Washer (80) over the splined hub of the Chain Wheel.
5. Press the Chain Wheel Splined End Bearing (79) on the splined hub of the Chain Wheel until it contacts the Washer.

#### Assembly of the Planet Gear Frame

1. Press a new Planet Gear Bearing (83) into each end of the Planet Gears (82). Seat each Bearing 1/64 in. (0.5 mm) below the face of the Gear.
2. Work a liberal amount of **Ingersoll-Rand** No. 11 Grease into the bore of the Planet Gear Bearings, making certain that each of the individual needles or rollers are covered.
3. Stand the Planet Gear Frame (81) on the table of an arbor press with its short hub upward.
4. Wipe a thin film of **Ingersoll-Rand** No. 11 Grease on both faces of one of the Planet Gears, and place a Planet Gear Thrust Washer (84) against each face. The grease will retain it in position.
5. Slide the Planet Gear, large diameter upward, and Thrust Washers into one side of the Planet Gear Frame and press in a Planet Gear Shaft (85).

### NOTICE

• **The direction of press is important. The holes in the web of the Gear Frame are slightly tapered to retain the Planet Gear Shaft. Make certain you press the Shafts in from the short hub end of the Gear Frame.**

6. Install the second Planet Gear with its Thrust Washers.
7. Stand the Planet Gear Frame on its short hub and press the Gear Frame Bearing (86), retainer ring first, onto the long hub.
8. Press the Brake Driver Bearing (87) into the bore of the Planet Gear Frame.
9. Work a liberal amount of **Ingersoll-Rand** No. 11 Grease into the bore of the Brake Driver Bearing, making certain that each individual needle or roller is covered.

#### Assembly of the Motor

1. Install the Motor Shaft Front Retaining Ring (75) in the annular groove near the center of the Motor Shaft (64).
2. Grasp the Motor Shaft vertically in copper-covered vise jaws so that the short-splined end is upward.
3. Press the Front End Plate Bearing (73) into the Front End Plate (72), and the Rear End Plate Bearing (66) into the Rear End Plate (67).
4. Slide the Front End Plate and Bearing, bearing side first, down over the Motor Shaft until it seats against the Motor Shaft Front Retaining Ring.

5. Slide the Rotor (68) counterbored end first down over the Motor Shaft until it contacts the Front End Plate.
6. Place a Vane (69) and Vane Spring (69A) in each vane slot in the Rotor.
7. Set the Cylinder (70) down over the Rotor, aligning the dowel hole in the Cylinder with the dowel hole in the Front End Plate.
8. Slide the Rear End Plate and Bearing, flat side first, onto the hub of the Motor Shaft until it contacts the Cylinder. Align the dowel hole in the Rear End Plate with the dowel hole in the Cylinder.
9. Install the Motor Shaft Rear Retaining Ring (65) in the annular groove on the end of the Motor Shaft.
10. Insert a 1/8 in. (3 mm) steel guide rod about 3 in. (76 mm) long through the dowel holes in the End Plates and Cylinder to maintain alignment of parts, and remove the assembly from the vise.

### Assembly of the Brake Mechanism

1. Lightly coat the Piston Seals (100 and 101) with O-ring lubricant, and install them in their respective grooves on the Brake Piston (99).
2. Taking care not to cut the Seals, slide the Piston into the Brake Spring and Piston Housing (96).
3. Place the Spring and Piston Housing on the workbench so that the three spring cavities are upward.
4. Place a Spring (97) in each cavity.
5. **For new style Pressure Plates (98)**, install the Pressure Plate Screw (98A) so that the screw head enters the counterbore in the Pressure Plate. Place the Pressure Plate and Screw over the Springs so that the Screw enters the hole in the Brake Piston.  
**For old style Pressure Plates with integral stud**, place the Pressure Plate, stud side first, over the Springs so that the stud enters the hole in the Brake Piston.

### NOTICE

• For improved brake control it is recommended that the old style pressure plate be replaced with the new style pressure plate (98) and screw (98A).

6. Using a vise, carefully compress the Pressure Plate against the Brake Spring and Piston Housing until the Screw or stud protrudes through the Piston. Start the Piston Nut (98B) onto the Screw or stud.
7. Remove the assembly from the vise.
8. **For new style Pressure Plates**, tighten the Pressure Plate Screw and Piston Nut until a .006 to .012 in. (0.15 to 0.30 mm) gap exists between the Pressure Plate and Piston. See Dwg. MHTPA0488.  
**For old style Pressure Plates**, tighten the Piston Nut to 50 to 70 in-lb (5.7 to 7.9 N.m) torque.

Brake Spring and Piston Housing Assembly

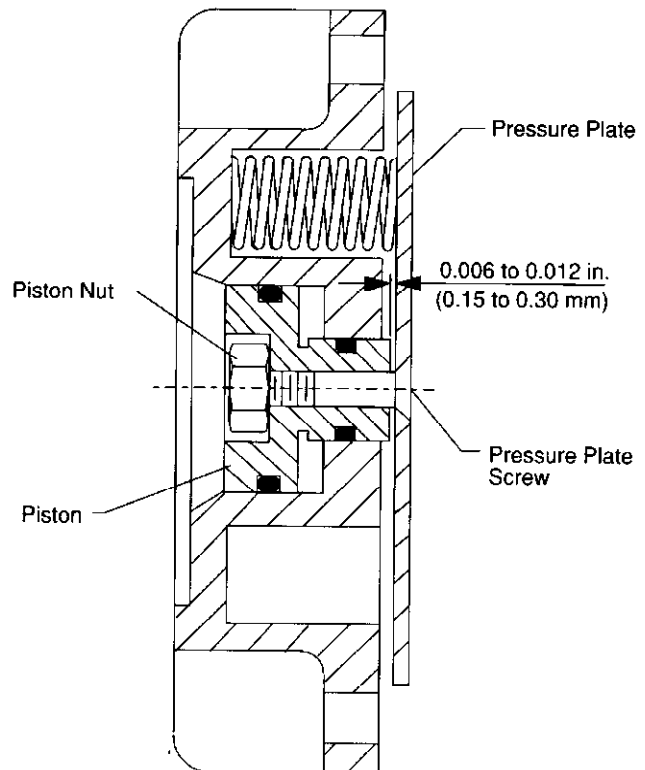

(Dwg. MHTPA0488)

### NOTICE

• Make certain the Piston extends completely through the Spring and Piston Housing and contacts the Pressure Plate.

9. Place the Plate (103) in the recess of the Spring and Piston Housing, and install the Plate Screws (104).

**Assembly of the Valve Chest used on Hoists with second letter of the Serial Number other than A through G or with second and third letters of the Serial Number other than HA, HB, HC or Hoist updated with new style Valve Chest Kit No. MLK-K545B.**

1. If the Valve Chest Cover Pins (32) were removed, install them in the bottom of the Valve Chest (14).
2. Apply a thin film of O-ring lubricant to the Valve Seals (16 and 18) and install them on the Valves (15 and 17).

### CAUTION

• Do not substitute any other O-rings for these Seals.

3. Install a Valve Spring (19) on the non-tapered end of each Valve and insert the Valves, Valve Spring first, into the openings at the bottom of the Valve Chest. Make certain the Valve marked UP is inserted into the opening marked UP VALVE and the Valve marked DOWN is inserted in the opening marked DOWN VALVE.

### NOTICE

- **Some early manufactured Valves are not marked UP and DOWN. If you have a set of unmarked Valves, the Valve with a shallow annular groove around the hub that fits into the Valve Spring is the DOWN Valve. The Valve with no annular groove is the UP Valve.**
4. Apply a thin film of O-ring lubricant to the Valve Seat Shaft Seals (22) and install one Seal in each Valve Seat (20).
  5. Apply a thin film of O-ring lubricant to the Valve Seat Seals (21) and install two Seals on each Valve Seat.
  6. Align the smaller diameter crosshole of the Valve Seat with the threaded hole in the side of the Valve Chest for the Valve Seat Lock Screw (23). With the hub end trailing, install the Valve Seats in the Valve Chest.
  7. Screw the Valve Seat Lock Screws into the Valve Chest. Make certain they enter the Valve Seats and torque the Screws to 24 in-lb (2.7 N.m).
  8. Using retaining ring pliers and applying pressure to the hub of the Valve Seat, install the Valve Seat Retainers (24). Make certain the Retainers seat in the grooves of the Valve Chest.
  9. If the Pistons (26) were separated from the Piston Shafts (28), apply a thin film of O-ring lubricant to each Piston Shaft Seal (29) and install them in the grooves of the Piston Shafts.
  10. Slide the Pistons onto the Piston Shafts with the small hub of the Piston toward the smallest diameter of the Shaft. Align the crosshole in each Piston with the crosshole in each Shaft and install the Piston Retaining Pins (30).
  11. Apply a thin film of O-ring lubricant to the Piston Seals (27) and install one on each Piston.
  12. Apply a thin coat of O-ring lubricant on the piston cylinder walls and insert the Piston Springs (25) into the Valve Chest against the Valve Seat Retainers.
  13. Install the assembled pistons and shafts in the Valve Chest.
  14. Apply a thin coat of O-ring lubricant to the Valve Chest Cover Seals (34) and install them in the Valve Chest Cover (33).
  15. Align the Valve Chest Cover Gasket (31) with the Valve Chest Cover Pins and place the Gasket against the Valve Chest.
  16. Align the Valve Chest Cover with the Valve Chest Cover Pins and Piston Shafts and place the Cover against the valve Chest.

17. Install the six Valve Chest Cover Screws (37) and torque them evenly to 6 ft-lb (8 N.m).
18. Thread the Adjustment Screw Locknuts (36) onto the Bleed Adjustment Screws (35) and install the Screws in the Valve Chest Cover.

### NOTICE

- **These Screws will require adjustment on Hoists having a Pendent Control. Refer to adjustment of Bleed Screws on Pendent Control Models in "INSTALLATION" section.**

19. Manually work the Piston Shafts up and down to ensure there is no binding of parts.

**Assembly of the Valve Chest used on Hoists with second letter of the Serial Number A through G or with second and third letters of the Serial Number HA, HB or HC.**

### NOTICE

- **Parts for this style valve chest may no longer be available. To replace with current style valve chest order kit no. MLK-K545B (03835519). The following assembly instructions are provided for reference only.**

1. Moisten the Valve Sleeve Seals (326) with O-ring lubricant and install them on the Valve Sleeves (325).

Each Valve Sleeve has a notch in one end and a 7/16 in. (11 mm) diameter port in the wall of the Sleeve. Inside the Valve Chest there is a 7/16 in. (11 mm) diameter cross-port that connects the two valve chambers.

2. Insert the Valve Sleeves, notched end first, into the Valve Chest so that the 7/16 in. (11 mm) diameter port in each Sleeve is aligned with the cross-port in the Valve Chest, and so that the notches in the Sleeves face each other.
3. Stand the Valve Chest up on the inlet port and insert a Valve Spring (327) and a Valve (325) into each Valve Sleeve. Make certain each Valve goes into its proper Sleeve. These are matched sets.
4. Moisten each Piston Seal (331) with O-ring lubricant and install a Seal in the groove on each Piston (330).
5. Insert each Piston Rod (328 and 329), small end first, through its respective hole in the Piston.
6. Install a Piston Nut (332) on each Piston Rod. Tighten the Nut to a snug fit.
7. Moisten the Valve Chest Cover Seals (335) with O-ring lubricant, and install them in the Valve Chest Cover (334).

8. Position the Valve Chest Cover so that the bleed holes and Adjustment Screws (336) are facing you. Moisten the large diameter of the Piston Rods with O-ring lubricant. Insert the longer Piston Rod (328) through the hole on the left from the gasket side of the Valve Chest Cover. Insert the shorter Piston Rod (329) through the hole on the right from the gasket side.
9. Place a Piston Spring (333) in each valve cavity in the Valve Chest, and position the Valve Chest Cover Gasket (338) on the bottom of the Valve Chest.
10. Taking care not to pinch the Piston Seals, install the assembled Valve Chest Cover to the bottom of the Valve Chest. Check to make sure the long stem Piston Rod (328) is installed in "UP VALVE" side as marked on gasket face of Valve Chest. Tighten the Valve Chest Cover Screws (339) evenly a little at a time until all are tight.

### Assembly of Hoist

1. Place the Chain Guard (13) in position in the Housing (1), and install the two Chain Guard Screws (13A) and Lockwashers (13B).
2. Install the assembled Chain Wheel (76), small bearing end first, into the brake end of the Housing (1). Tap the Chain Wheel lightly on its trailing end to make certain the Plain End Bearing (77) is fully seated.
3. Install a Brake Housing Bolt Seal (90A) into each of the four bolt holes in the Brake Housing (90) so that the tapered end of each Seal faces the shoulder side of the Brake Housing.
4. Align the bolt holes in the flange of the Ring Gear (88) with the bolt holes in the Brake Housing, and press the Ring Gear, flange side first, onto the shoulder of the Brake Housing.

### ⚠ CAUTION

- It is very important that the Planet Gears (82) and Ring Gear be aligned when the Gear Frame Assembly is inserted into the Ring Gear.

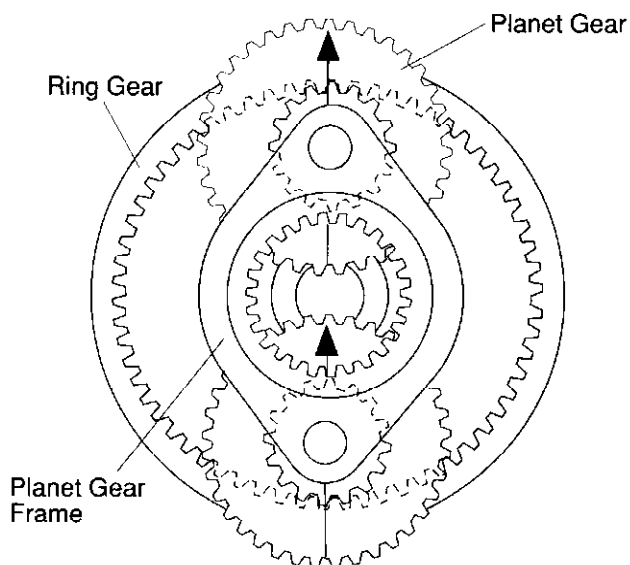

(Dwg. TPD35-1)

5. Align the gearing as follows:
  - a. Stand the Ring Gear and Brake Housing upright.
  - b. Align the arrows and scribe lines on the faces of the Planet Gears in a straight line as shown in Dwg. TPD35-1.
  - c. While maintaining this alignment, insert the Gear Frame Assembly, bearing end first, into the Ring Gear seating the Gear Frame Bearing (86) in the Brake Housing.
6. Apply a thin film of grease on the Ring Gear Gasket (89) and place the Gasket on the face of the Ring Gear.
7. While holding the entire assembly so that the Planet Gears (82) are aligned with the cutout areas in the Housing (1), install the assembly in the Housing so that the splined hub of the Gear Frame engages the splined hub on the Chain Wheel.
8. Place the Motor Retaining Washer (63) dished (concave) side first, against the Front End Plate and engage the dowel hole in the Washer with the guide rod.
9. While aligning the guide rod with the dowel hole in the bottom of the housing bore, slide the assembled motor into the Housing so that the Motor Shaft (64) passes through the Chain Wheel and meshes with the Planet Gears.
10. Withdraw the guide rod from the motor and install the Cylinder Dowel (71) so tapered end enters first.
11. Insert the Mufflers (49) into the recess in the Valve Chest Plate (46).
12. Place the Housing Gasket (9) onto the motor end of the Housing and install the Valve Chest Plate with the Valve Chest Plate Screws (48).
13. Slide the Brake Driver (92) on the splined end of the Motor Shaft and install the Brake Driver Retainer (93).
14. Manually, rotate the Brake Driver several revolutions to make certain the Planet Gears are properly aligned and properly meshed with the Motor Shaft and the Motor rotates freely.
15. Insert the Brake Tube (57) in the hole in the boss at the upper right-hand corner of the Brake Housing and install a Brake Tube Seal (58) on each end of the Brake Tube.
16. Place a Brake Plate (94) followed by a Brake Disc (95), Brake Plate, Brake Disc and two Brake Plates over the Brake Driver, aligning the notches in the Brake Plates with the bolt holes in the Brake Housing and main Housing.
17. Insert the Brake Tube Housing Seal (59) into the hole in the boss of the Brake Spring and Piston Housing (96). Install the assembled Brake Spring and Piston Housing, making certain that the Brake Tube enters the hole in the base on the Housing. Align the bolt holes in the Brake Spring and Piston Housing with those in the Brake Housing and install the four Shoulder Bolts (105) and Lockwashers (106).



18. Stand the Hoist upright on the brake end. Place the Valve Chest Gasket (43) on the Valve Chest Plate, making certain that the small flapper is properly positioned in the recess between the two ports.

### CAUTION

**- If the Valve Chest Gasket is flipped over, the flapper will not be in the recess between the two ports, and the brake will not release.**

19. Center the two round rubber discs in corresponding recesses in the Valve Chest Plate.
20. Place the assembled Valve Chest (14) on the Valve Chest Gasket, and install the Valve Chest Screws (44 and 45).
21. Position the Chain Guide (10) underneath the Chain Wheel, and install the Chain Guide Screws (11).
22. Place the Throttle Shaft Spring (56) over one hub of the Throttle Lever (53) so that the bent leg of the Spring is toward the inside of the Throttle Lever.
23. Hold the Throttle Lever in the housing recess beneath the Chain Wheel so that the Throttle Shaft Spring is toward the Valve Chest end of the Hoist and the legs of the Spring engage a rib on the bottom of the Chain Guide. Place a Throttle Lever Thrust Washer (55) at each end of the throttle lever bore, and insert the Throttle Shaft (50), round end first, through the Valve Chest Plate, Housing and Throttle Lever. Install the Throttle Lever Retaining Pin (54). Throttle Shaft (50) has two cross holes. On MLK hoists ensure Throttle Lever Retaining Pin (54) locates in the hole nearest the stepped end of the Throttle Shaft (50).
24. Place the Limit Actuator (51) on the square end of the Throttle Shaft, and install the Limit Actuator Retaining Pin (52).
25. **For all Hoists with second letter of the Serial Number other than A through G or with second and third letters of the Serial Number other than HA, HB or HC, install the two Pendant Links (223) between the Limit Actuator and the Valve Shafts. For Pendant Control Hoists with second letter of the Serial Number A through G or with second and third letters of the Serial Number HA, HB or HC, install a Pendant Link (223) between the Limit Actuator and the Long Piston Rod. For Pull Chain Control Hoists with second letter of the Serial Number A through G or with second and third letters of the Serial Number HA, HB or HC, no Pendant Links are required.**
26. Apply a thin film of O-ring lubricant to the two Swivel Inlet Seals (40 or 342) and install them in the grooves of the Inlet Nipple (39 or 341).
27. Being careful to prevent cutting the Seals, push the Inlet Nipple into the Inlet Body (38 or 340).
28. Apply a thin film of O-ring lubricant to the Swivel Inlet Gasket (41 or 343) and install the Gasket on the Nipple.

29. Thread the Inlet Assembly into the top of the Valve Chest and tighten it.
30. Thread the Inlet Strainer (42 or 344) into the Inlet Body and tighten it.

### Pendant Installation

### WARNING

**• Disconnect the hoist from the air supply before installing this pendant control kit.**

When installing pendant assembly on an ML25K, ML50K or ML100K Hoist, a crimping tool (Part No. ML50K-930AT or a Nicopress Tool with Groove Size J) must be used to install the upper stop sleeve. A crimping tool (Part No. ML100K-930AT or a Nicopress Tool with Groove Size G) must be used to install the clamping sleeve (216) on the lower end of the strain relief cable (215). The stop sleeve must be installed on the upper end of the strain relief cable (215). If necessary, trim the lower portion of the valve chest cover (Part No. ML500K-251) to provide strain relief cable clearance.

The strain relief cable (215) must be long enough to allow the pendant hose to hang nearly straight yet short enough to absorb the pendant weight and forces.

When the control hoses are cut to length, the hose at the rear of the handle should extend 6 in. (150 mm) beyond the top clamping thimble. Depending upon which valve chest is used on the hoist, the length of the two hoses at the front of the handle will vary. With an MLK-A545A valve chest, the hoses should extend 2 in. (51 mm) beyond the top clamping thimble (217). With an MLK-A545 valve chest, the hoses should extend 4 in. (100 mm) beyond the top clamping thimble (217).

Install one hose tie (218) above the pendant handle (200) and one hose tie below the clamping thimble (217). Install the remaining hose ties every 2-1/2 feet (0.76 m) between the hose ties at the handle and thimble.

When installing the warning plate (220), ensure the plate can be read from the lever side of the pendant handle.

### Load Test

Prior to initial use, all new, extensively repaired, or altered hoists shall be load tested by or under the direction of a qualified person, and a written report furnished confirming the rating of the hoist. Dynamically load test hoist to 100% of its rated capacity in accordance with ASME B30.16 standards. Testing to more than 100% may be necessary to comply with standards and regulations set forth in areas outside of the USA.

# HOIST ASSEMBLY DRAWING

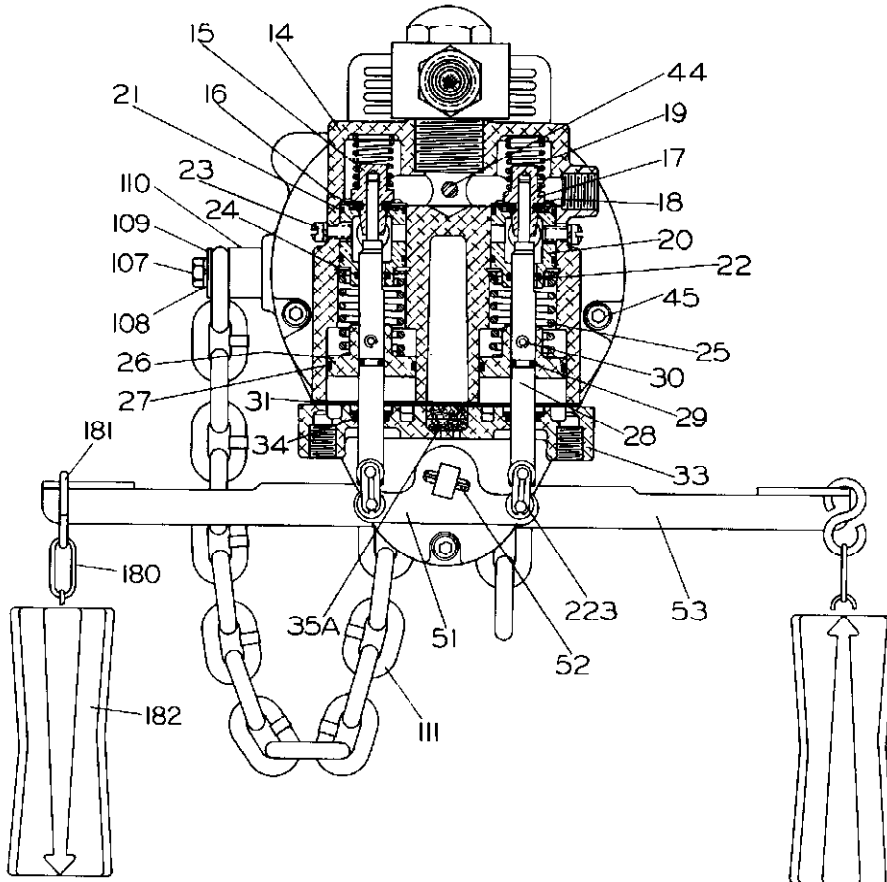
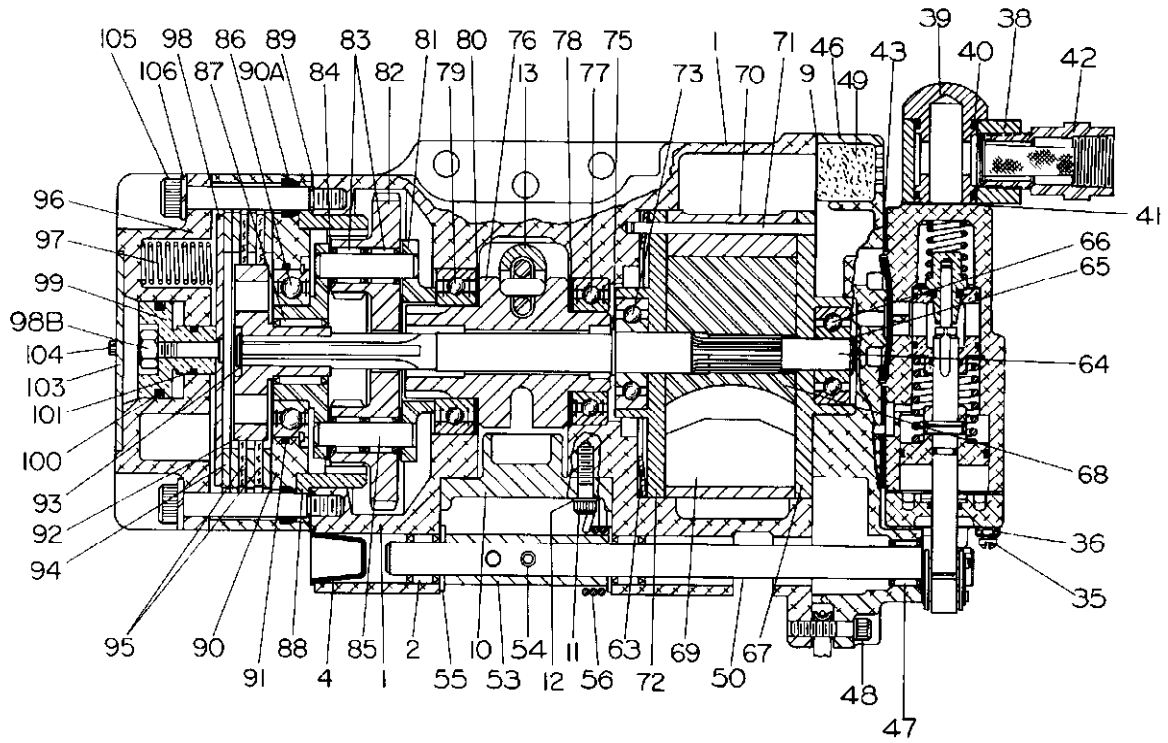

(Dwg. TPA823-5)

**Valve Chest shown for Hoists with second letter of the Serial Number other than A through G or with second and third letters of the Serial Number other than HA, HB or HC.**

## HOIST ASSEMBLY PARTS LIST

ITEM NO.	DESCRIPTION OF PART	TOTAL QTY.	PART NO.	ITEM NO.	DESCRIPTION OF PART	TOTAL QTY.	PART NO.
1	Housing Assembly	1	ML50K-A300	• 40	Swivel Inlet Seal	2	R4-210
• 2	Throttle Shaft Bearing	2	R38M-603	• 41	Swivel Inlet Gasket	1	R18LF-21
*	Vent Plug	1	P250-546	42	Inlet Strainer	1	MLK-82
4	Throttle Shaft Plug	1	ML50K-29	• 43	Valve Chest Gasket +(2 round)	1 Set	MLK-928-80
*	Nameplate	1	MR-301S	44	Valve Chest Screw	1	518-104
*	Nameplate	1	MR-301M	45	Valve Chest Screw	2	R0H-354-4
*	Nameplate Screw	4	R4K-302	46	Valve Chest Plate	1	MLK-549
*	Caution Tag	1	TA-147A	• 47	Throttle Lever Bearing	1	R38M-603
*	Caution Tag Screw	4	R4K-302-12	48	Valve Chest Plate Screw	5	5080-638-4
• 9	Housing Gasket	1	ML50K-445	49	Muffler	2	MLK-175
10	Chain Guide	1	ML-741C	50	Throttle Shaft	1	MHLK-255
11	Chain Guide Screw	4	34U-463-4	51	Limit Actuator	1	MLK 251A
12	Lockwasher	4	4U-58-10	52	Limit Actuator Retaining Pin	1	WF171-15
13	Chain Guard	1	ML-6A	53	Throttle Lever	1	ML50K-556
13A*	Guard Retaining Screw	2	G57T-634	54	Throttle Lever Retaining Pin	1	WF171-15
13B*	Lockwasher	2	L01-67-10	55	Throttle Lever Thrust Washer	2	MR-458
---	Valve Chest Assembly	1	MLK-A545B	56	Throttle Shaft Spring	1	MR-412
14	Valve Chest	1	MLK-545A	57*	Brake Tube	1	ML50K-401
15	Up Valve Assembly	1	MLK-K102U	58	Brake Tube Seal	2	ML50K-21
• 16	Up Valve Seal	1	MLK-211	59	Brake Tube Housing Seal	1	PS3-67
17	Down Valve Assembly	1	MLK-K1102D	63	Motor Retainer Washer	1	MR-207
• 18	Down Valve Seal	1	MLK-211	---	Motor Assembly	1	MLK-A53
19	Valve Spring	2	MLK-942A		ML250K ML500K and ML1000K		MLK-A53
20	Valve Seat Assembly	2	MLK-K615		ML250KR, ML250KS, ML500KR, ML500KS and ML1000KS		MLK-AR53A
• 21	Valve Seat Seal	2	C321-606	64	Motor Shaft	1	ML50K-316
• 22	Valve Seat Shaft Seal	1	R000BR-210	• 65	Motor Shaft Rear Retaining Ring	1	MLK-120
23	Valve Seat Lock Screw	2	AF160-305	• 66	Rear End Plate Bearing	1	R2-24
• 24	Valve Seat Retainer	2	MLK-218	67	Rear End Plate	1	MR-12
25	Piston Spring	2	MLK-250A	68	Rotor	1	MR-53
26	Piston Assembly	2	MLK-K246A	• 69	Vane Packet with Springs	1 Set	MLK-K4243-7
• 27	Piston Seal	1	H1K-103	69A	Vane Springs	1 Set	MLK-43-7
28	Piston Shaft Assembly	2	MLK-K655A	70	Cylinder	1	MR-3A
• 29	Piston Shaft Seal	1	R0BR1C-283		ML250K ML500K and ML1000K		MLK-R3
30	Piston Retaining Pin	1	510-669A		ML250KR, ML250KS, ML500KR, ML500KS and ML1000KS		MLK-R3
31	Valve Chest Cover Gasket	1	MLK-117A	71	Cylinder Dowel	1	R3H-434
32	Valve Chest Cover Pin	2	MLK-241	72	Front End Plate	1	MR-11
33	Valve Chest Cover Assy	1	MLK-A238A	• 73	Front End Plate Bearing	1	TB-394
• 34	Valve Chest Cover Seal	2	R000BR-210	• 75	Motor Shaft Front Retaining Ring	1	MLK-119
35	Bleed Adjustment Screw	2	MLK-370	76	Chain Wheel	1	ML-740B
35A	Muffler	2	MLK-236	• 77	Chain Wheel Plain End Bearing	1	MR-593
36	Adjustment Screw Locknut	2	Q1-121	78	Chain Wheel Plain End Washer	1	MR-974
37	Valve Chest Cover Screw	6	MLK-240				
---	Swivel Inlet Assembly	1	MLK-A4				
38	Inlet Body	1	MLK-166				
39	Inlet Nipple	1	MLK-B4				

\* Not shown on drawing

• Recommended Spare

Parts list continued on next page

## HOIST ASSEMBLY PARTS LIST

ITEM NO.	DESCRIPTION OF PART	TOTAL QTY.	PART NO.	ITEM NO.	DESCRIPTION OF PART	TOTAL QTY.	PART NO.		
* 79	Chain Wheel Splined End Bearing	1	MR-988	105	Shoulder Bolt	4	ML50K-7		
80	Chain Wheel Splined End Washer	1	MR-975	106	Lockwasher	4	DO2-321-10		
---	Gear Frame Assembly	1	ML25K-A8	107	Chain Anchor Bolt	1	SM450-744		
	ML250K and ML250KS			108	Lockwasher	1	L01-67-10		
	ML500K, ML500KS, ML1000K, ML1000KS, ML250KR and ML500KR			109	Flat Washer	1	B12-265		
81	Planet Gear Frame	1	ML25K-8	110	Chain Anchor Bolt Spacer	1	ML50K-145		
	ML250K and ML250KS			111	Load Chain	When ordering "length as specified" chain for ML250KS, ML500KS or ML250KR Hoists, specify a chain length 2 feet longer than the required lift. When ordering "length as specified" for ML1000KS or ML500KR Hoists specify a length 3 feet longer than twice the required lift. NOTE: Chains for the ML1000KS and ML500KR Hoists must contain an ODD number of links when installed on the Hoist.			
	ML500K, ML500KS, ML1000K, ML1000KS, ML250KR and ML500KR	ML50K-8							
82	Planet Gear	2	MR5-A10	standard chain	Specify length in feet				ML-745
	ML250K and ML250KS			zinc plated chain					ML-BZ745
	ML500K, ML500KS, ML1000K, ML1000KS, ML250KR and ML500KR	MR-A10	ML250KR and ML500KR only	Stainless Steel		ML-R745			
* 83	Planet Gear Bearing	2 ea gear	ML50K-654	*	1/4 ton Label (for ML250K)	1	ML25K-99		
84	Planet Gear Thrust Washer	4	ML50K-361	*	1/4 ton Label (for ML250KR)	1	ML25KR-99		
85	Planet Gear Shaft	2	MR-191	*	1/2 ton Label (for ML500K)	1	ML50K-99		
86	Gear Frame Bearing	1	ML50K-97	*	1/2 ton Label (for ML500KR)	1	ML50KR-99		
* 87	Brake Driver Bearing	1	ML50K-318	*	1 ton Label (for ML1000K)	1	ML100K-99		
88	Ring Gear	1	ML50K-406A	*	I-R Decal (for Valve Chest)	1	HRA20A-201		
* 89	Ring Gear Gasket	1	ML50K-31	*	Bleed Screw Adjustment Tag	1	TA-INS-150		
90	Brake Housing	1	ML50K-346	*	"Spark Resistant Tag" (for spark resistant Hoists only)	1	MLKR-33		
* 90A	Brake Housing Bolt Seal	4	ML50K-271	*	"Spark Resistant" Tag Fastener	2	CE110-4		
* 91	Brake Housing Bearing Seal	1	HRA20A-990	<b>PARTS FOR PULL CHAIN CONTROL</b>					
92	Brake Driver	1	ML50K-842	180	Pull Chain (specify total length for (2) Chains required)		---		
* 93	Brake Driver Retainer	1	ML50K-729		Standard Hoists	Specify length in feet	CA110-B240		
94	Brake Plate	4	ML50K-834A		Spark Resistant Hoists		D02-1413		
* 95	Brake Disc	2	ML50K-855A	---	Pull Chain Hardware Kit	1	MLK-K415		
96	Brake Spring and Piston Housing Assembly	1	MLK-A395A	181	S-Hook	4	D02-421		
97	Spring	3	ML50K-832	182	Throttle Handle	2	MR-415		
98	Pressure Plate	1	ML50K-K338A	183	1/4 in. Pipe Plug	1	ROH-377		
98A	Pressure Plate Screw	1	ML50K-805A	184	1/8 in. Pipe Plug	2	P250-546		
98B	Piston Nut	1	ML50K-394	*	Warning Plate	1	CA110-598		
99	Piston	1	ML50K-A809	*	Warning Plate Fastener	2	CE110-4		
* 100	Piston Large Seal	1	R2C-103						
* 101	Piston Small Seal	1	MLK-210						
103	Plate	1	ML50K-981						
104	Plate Screw	2	CE110-354						

\* Not Illustrated

\* Recommended spare

**HOIST SUB-ASSEMBLY PARTS DRAWINGS**

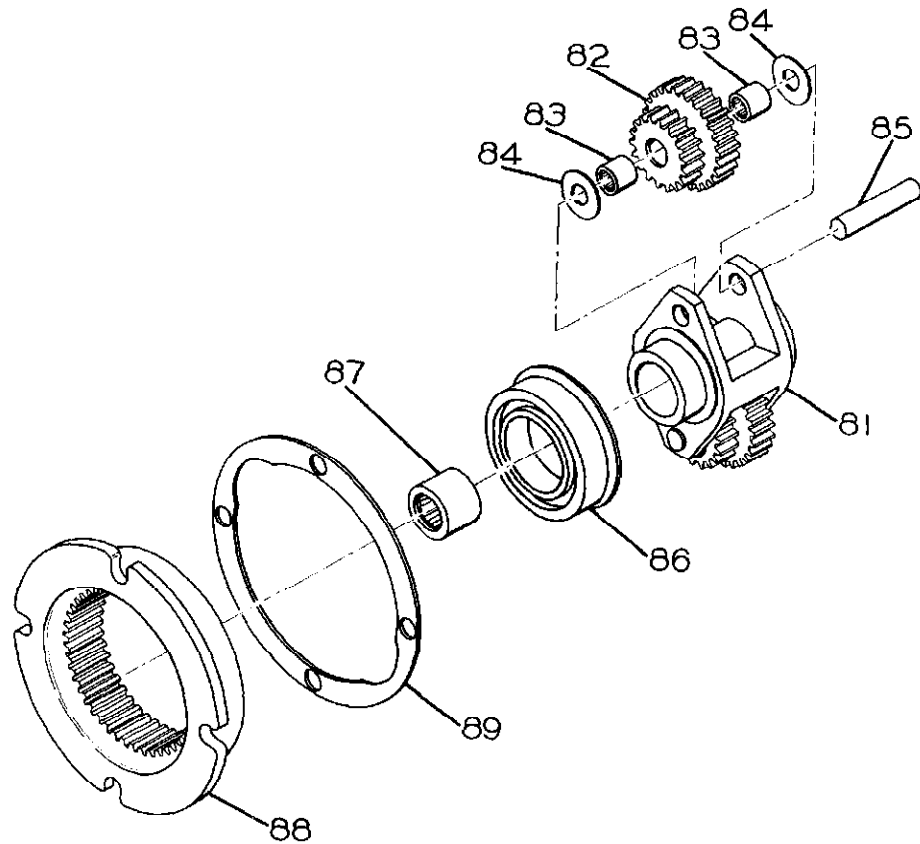

(Dwg. TPC396-2)

**Gearing for MLK Hoist**

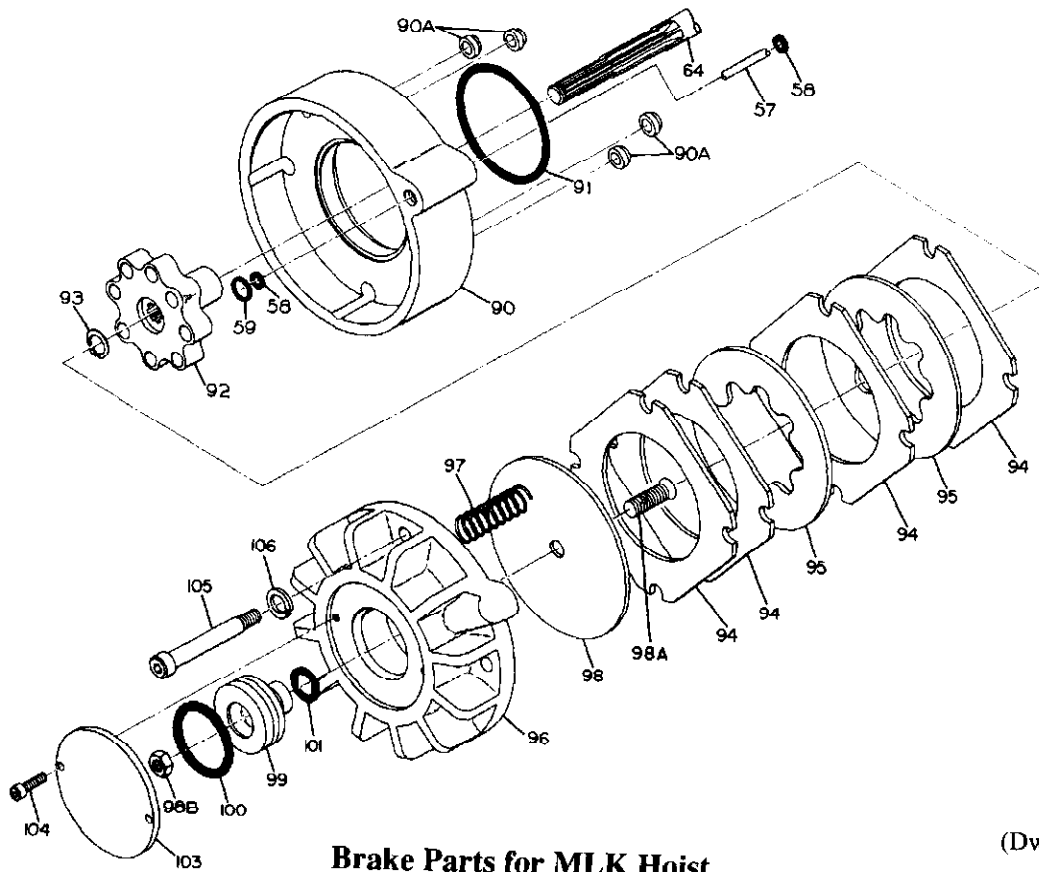

(Dwg. TPB613-4)

**Brake Parts for MLK Hoist**

# HOIST SUB-ASSEMBLY PARTS DRAWINGS

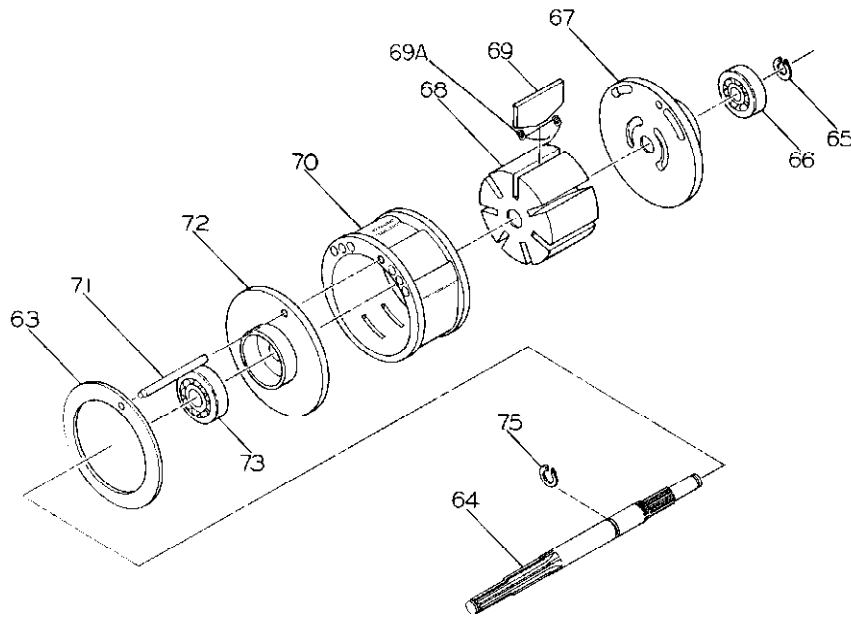

**Motor Parts for MLK Hoist**

(Dwg. TPB614 2)

**Chain Wheel Assembly for MLK Hoist**

(Dwg. TPC397-2)

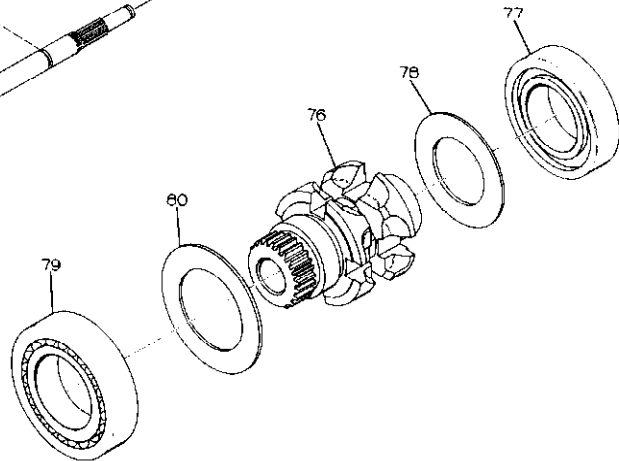

# HOIST VALVE CHEST ASSEMBLIES

Old and New Style Valve Chests may be identified externally by:

1. The location of the pendant connection ports.
2. The use of connector links for throttle control.

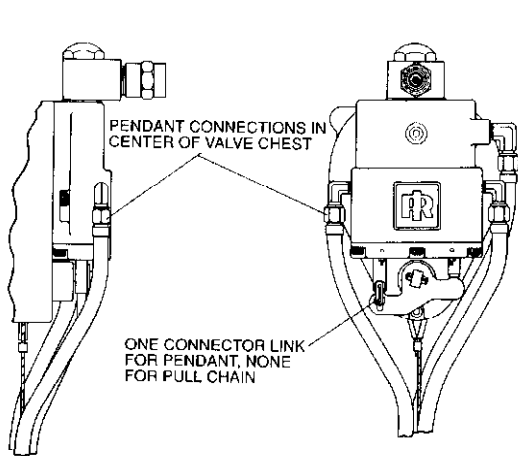

**Old Style**

(Dwg. TPB766)

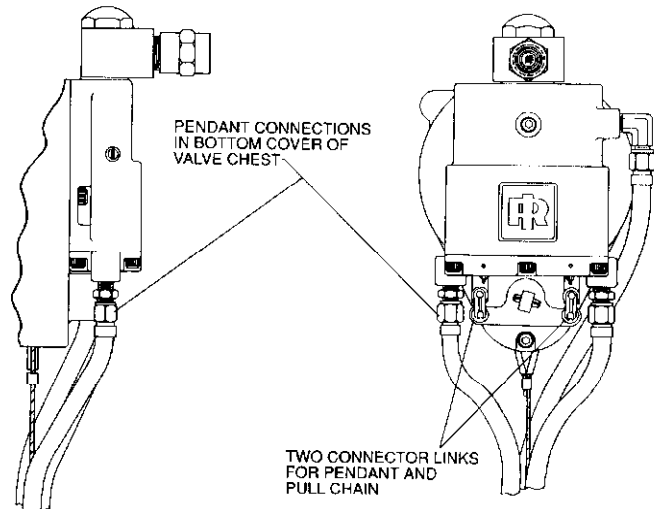

**New Style**

(Dwg. TPB767)

# HOIST SUB-ASSEMBLY PARTS DRAWINGS

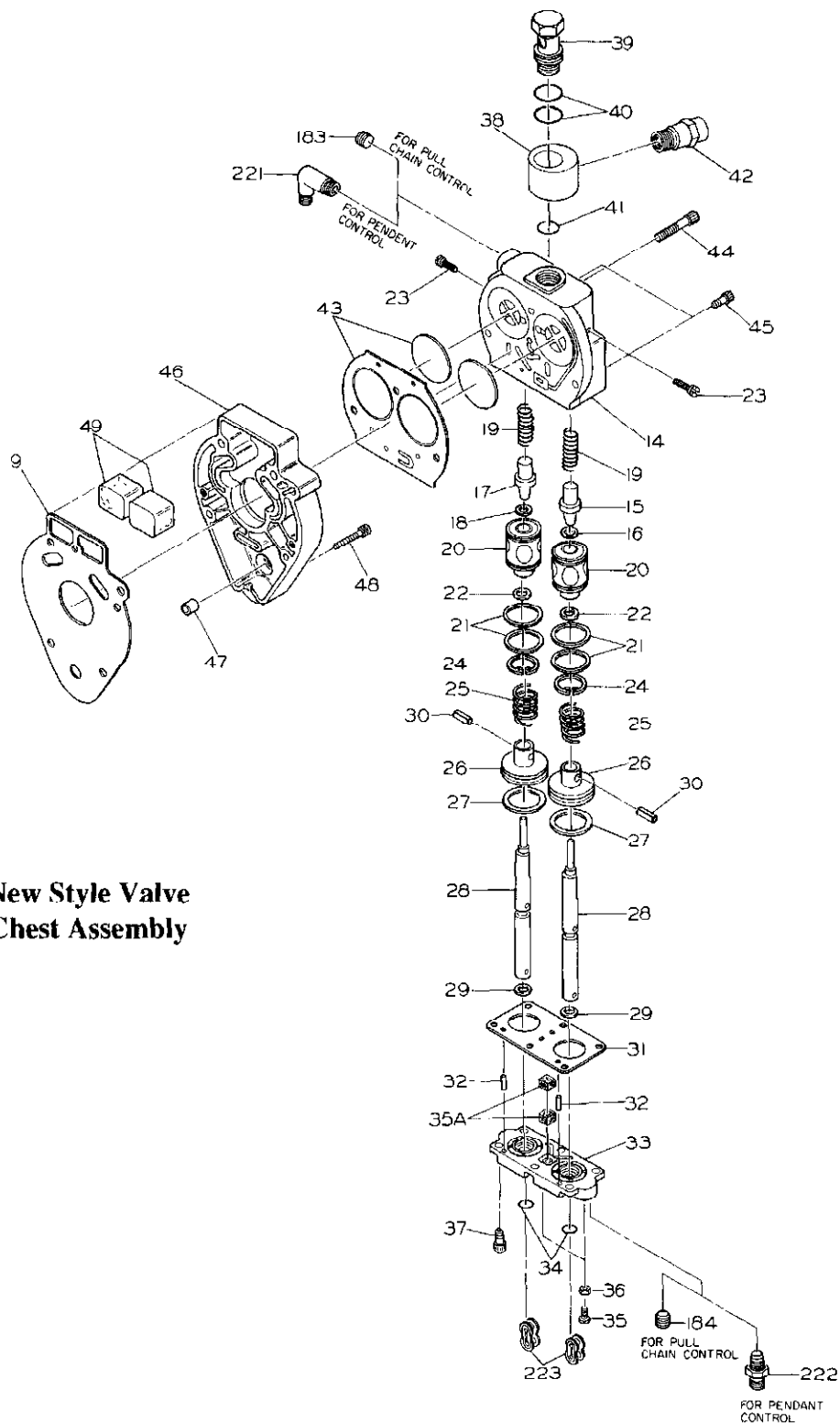

**New Style Valve Chest Assembly**

(Dwg. TPA949)

**Valve Chest Parts used on MLK Hoists with second letter of the Serial Number other than A through G or with second and third letters of the Serial Number other than HA, HB or HC. For Hoist with second letter of the serial number A through G or second or third letters of the serial number HA, HB or HC; valve chest parts may no longer be available and should be converted to the new style shown above with Kit No. MLK-K545B (03835519).**

# PENDANT AND HOSE ASSEMBLY DRAWING

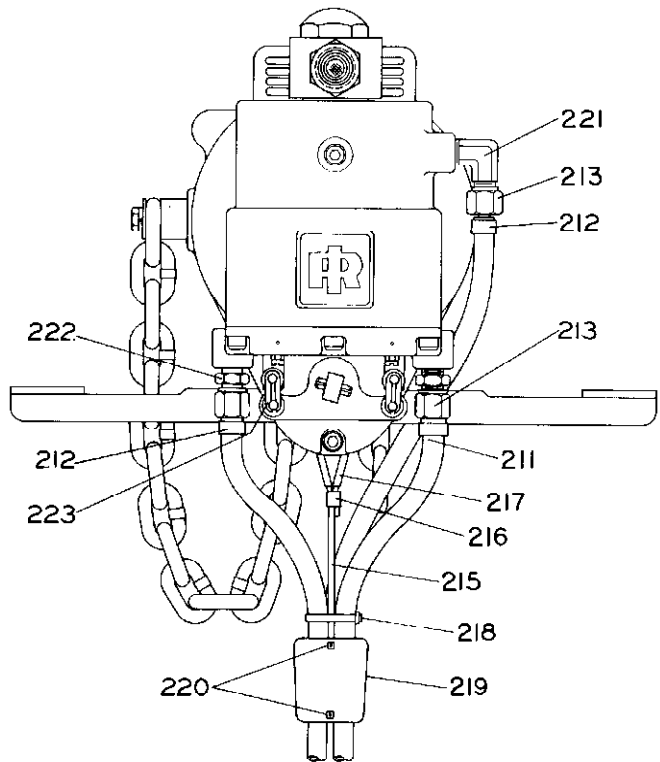

(Dwg. TPA824-4)

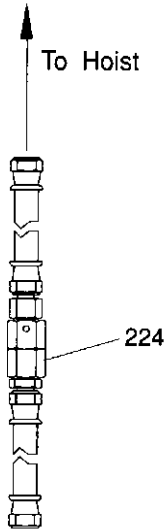

Typical Exhaust Valve Assembly

(Dwg. MHTPA0435)

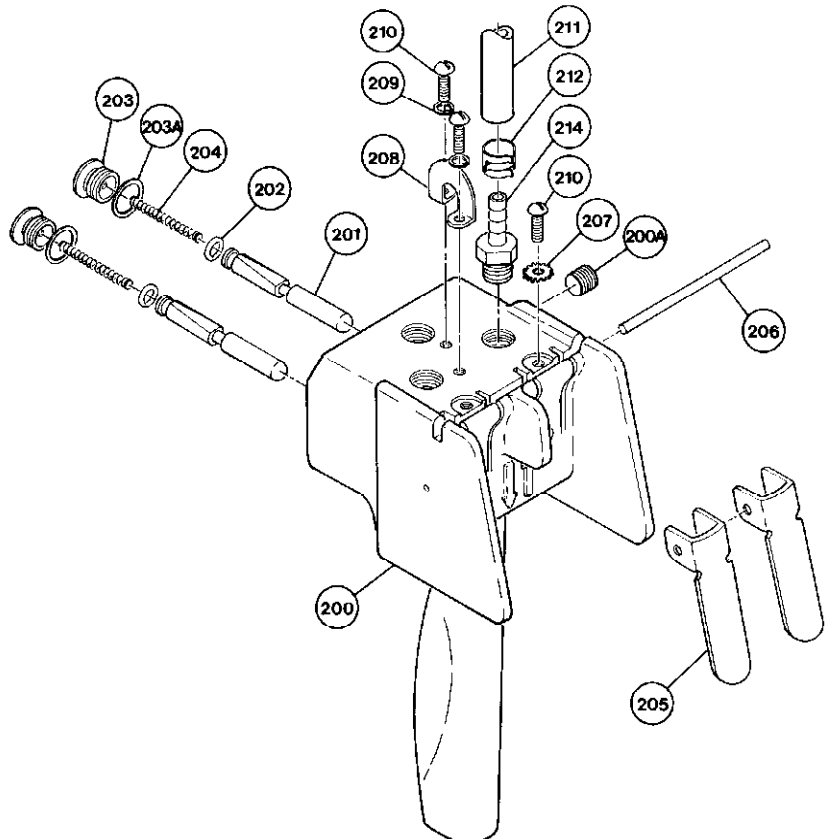

(Dwg. MHTPA0480)

## WARNING TO AVOID INJURY DO NOT-

- LIFT MORE THAN RATED LOADS
- LIFT PEOPLE OR LOADS OVER PEOPLE
- OPERATE WITH TWISTED, KINKED OR DAMAGED CHAIN
- OPERATE DAMAGED OR MALFUNCTIONING HOIST
- MAKE SURE CHAIN IS WITH MISALIGN CHAIN WITH HOIST
- OPERATE UNLESS TRAVEL LIMIT DEVICES FUNCTION ON TEST EACH SHIFT
- REMOVE OR OBSOLETE THIS WARNING LABEL

### READ

ANSI B30.16 SAFETY CODE FOR  
HOISTS AND HOIST MANUFACTURER'S  
INSTRUCTIONS

Warning Plate Item No. 219





# HOIST SUB-ASSEMBLY PARTS DRAWING

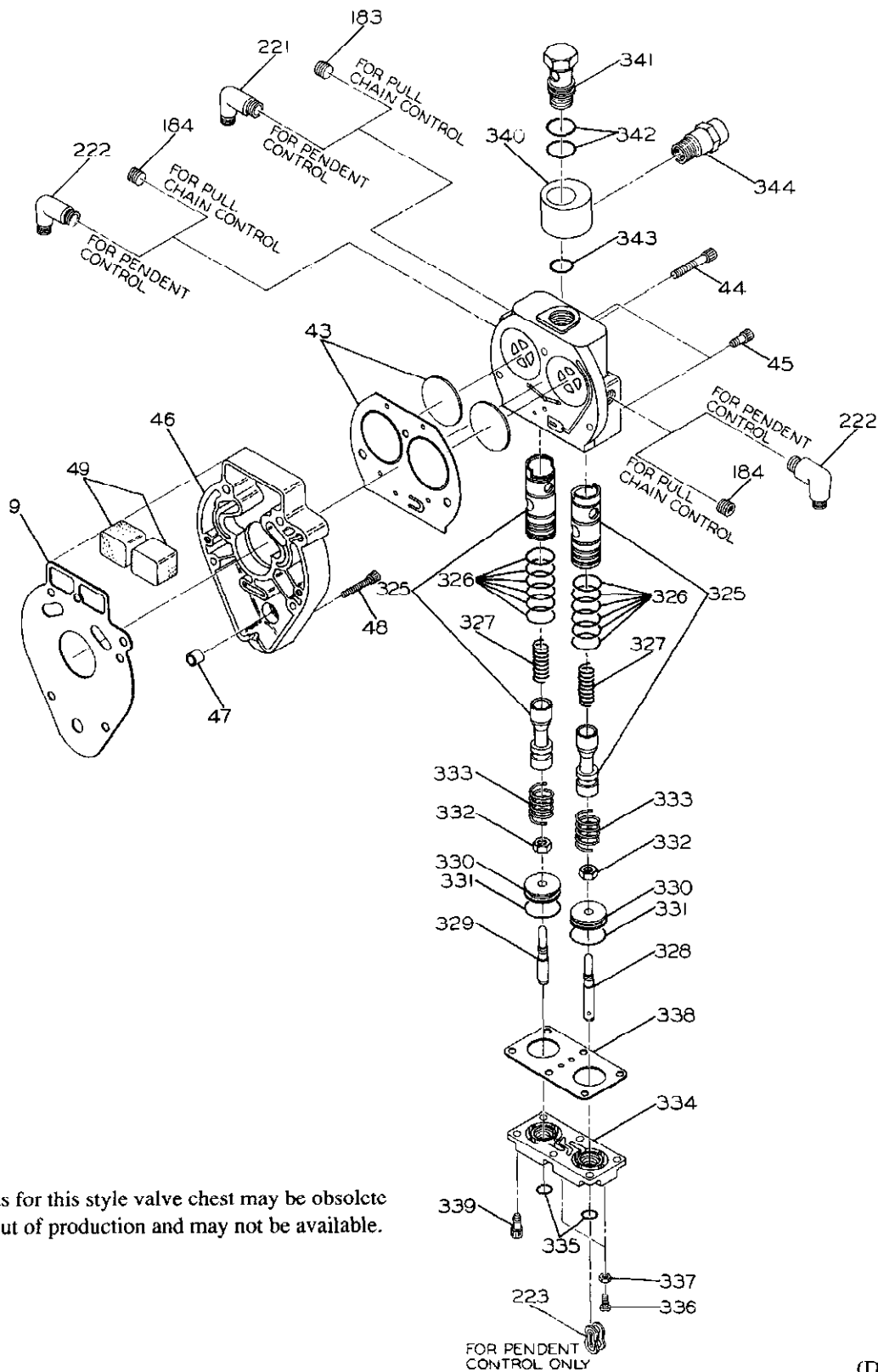

**NOTE:** Parts for this style valve chest may be obsolete or out of production and may not be available.

(Dwg. TPA822-3)

**Valve Chest Parts for ML250K, ML500K and ML1000K Hoists with second letter of the Serial Number A through G or with second and third letters of the Serial Number HA, HB or HC.**

## VALVE ASSEMBLY DRAWING AND PARTS LIST

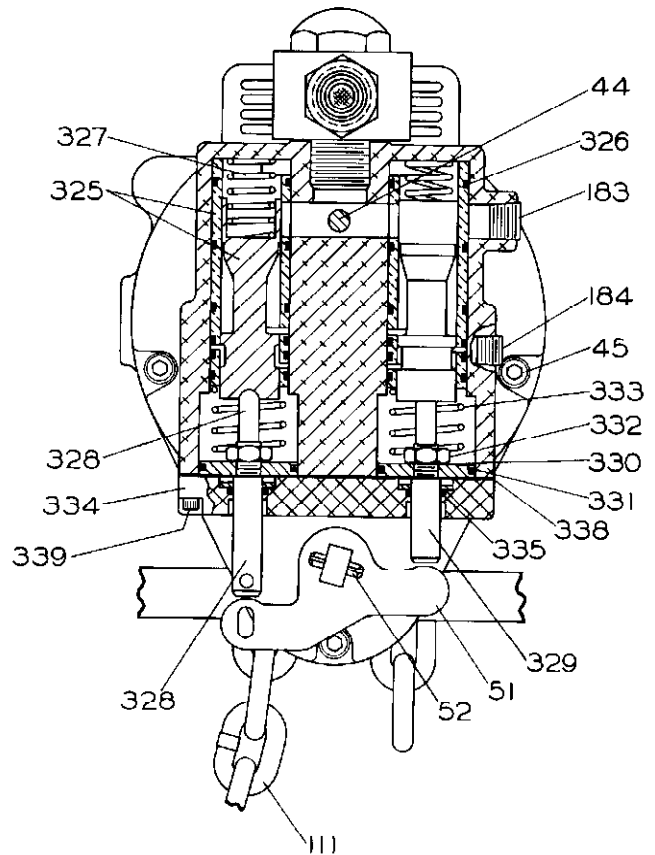
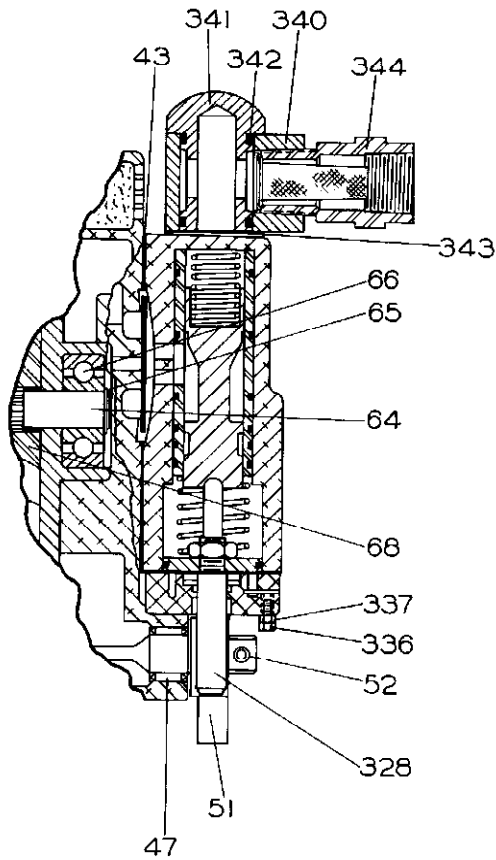

**NOTE:** Parts listed below (325 through 344) are for the older style valve chest may be obsolete or out of production and may not be available.

(Dwg. TPB730)

### Valve Chest Parts for ML250K, ML500K and ML1000K Hoists with second letter of the Serial Number A through G or with second and third letters of the Serial Number HA, HB or HC.

ITEM NO.	DESCRIPTION OF PART	TOTAL QTY.	PART NO.	ITEM NO.	DESCRIPTION OF PART	TOTAL QTY.	PART NO.
325	Valve and Valve Sleeve Assembly (old style)	2	Order conversion kit MLK-K545B	334	Valve Chest Cover	1	MLK-238
326	Valve Sleeve Seal	6 ea. sleeve	C321-606	335	Valve Chest Cover Seal	2	R000BR-210
327	Valve Spring	2	MLK-942	336	Bleed Adjustment Screw	2	4U-359
328	Long Piston Rod	1	MLK-655U	337	Adjustment Screw Locknut	2	Q1-121
329	Short Piston Rod	1	MLK-655D	338	Valve Chest Cover Gasket	1	MLK-117A
330	Piston	2	MLK-K246	339	Valve Chest Cover Screw	6	MLK-240
331	Piston Seal	1 ea. piston	HU-730	---	Swivel Inlet Assembly	1	MLK-A4
332	Piston Nut	2	MLK-256	340	Inlet Body	1	MLK-166
333	Piston Spring	2	MLK-250	341	Inlet Nipple	1	MLK-B4
				342	Swivel Inlet Seal	2	R4-210
				343	Swivel Inlet Gasket	1	R18LF-21
				344	Inlet Strainer	1	MLK-82

**NOTE:** If a complete Valve Chest Assembly is required for an ML250K, ML500K or ML1000K Hoist with the second letter of the Serial Number A through G or with the second and third letters of the Serial Number HA, HB, or HC, order a Valve Chest Conversion Kit MLK-K545B as described in "REPAIR AND CONVERSION KITS".

# SINGLE LINE HOIST HOOK ASSEMBLY DRAWING AND PARTS LIST

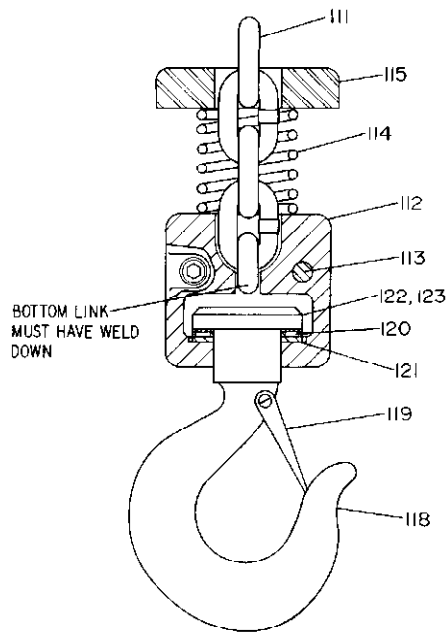

**Bottom Hook Assembly**

(Dwg. TPD669-3)

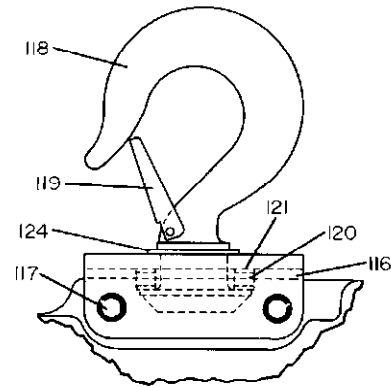

**Top Hook Assembly**

(Dwg. TPD576-2)

ITEM NO.	DESCRIPTION OF PART	TOTAL QTY.	PART NO.			
			STANDARD (1/2 t max)		SPARK RESISTANT (1/2 t max)	
			ML250K, ML250KS, ML500K and ML500KS		ML250KR	
*	Bottom Hook and Block Assembly	1	MLK-K463		MLK-KR463	
*	Hook Assembly	1	MLK-KS304		MLK-KRS304 (Bronze)	
112	Hook Block	2	MLK-463		MLK-R463 (Stainless)	
113	Bolt	2	MLK-461			
114	Spring	1	MKL-25 (Plated)			
115	Stop Ring	1	MLK-259		MLK-R259 (Aluminum)	
*	Top Hook Assembly	1	MLK-K463		MLK-KR463	
*	Hook Assembly	1	MLK-KS304		MLK-KRS304 (Bronze)	
116	Hook Yoke	1	MR10-590B			
• 117	Pin	2	MR-964			
	<b>Top or Bottom Hook Assembly</b>		<b>Standard Steel (1/2 t max)</b>	<b>Bronze (1/2 t max)</b>	<b>Bullard Burnham (1/2 t max)</b>	<b>Copper Plated (1/2 t max)</b>
*	Hook Assembly	1	MLK-KS304	MLK-KRS304	CE110-KBB377	MLK-KCPS304
118	Hook	1	CE110-KS304	CA-SR304	CE120-BB377X	MLK-CPS304
• 119	Latch Kit	1	MR10-S123	D01-S4055	---	MR10-S123
• 120	Bearing	1	R4810-105			
• 121	Thrust Washer	2	CE110-596			
122	Hook Nut	1	---	CA105-R305A		---
• 123	Nut Pin	1	---	MLK-826		---
• 124	Retainer (Top Hook Only)	1	MR10-375			

• Recommended Spare

\* Not illustrated

**NOTE:** Stop Ring (115) and Spring (114) are required on standard models ML250K and ML500K to absorb energy of full speed contact with the throttle lever as the "UP" limit is activated, and prevent damage to the hoist. For models ML250KS, ML250KR and ML500KS the Stop Ring (115) and Spring (114) may be removed, due to reduced operating speeds of these units. This will decrease the minimum hook to beam distance in the full up position by approximately 4 in. (100 mm).

# DOUBLE LINE HOIST HOOK ASSEMBLY DRAWING AND PARTS LIST

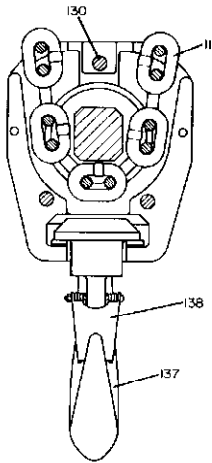

**Bottom Hook Assembly**

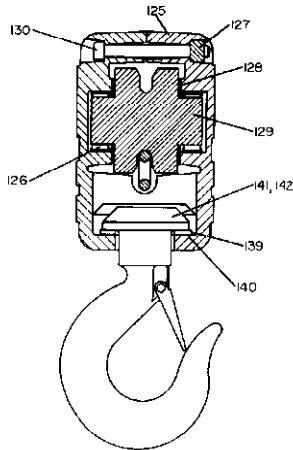

(Dwg. TPC401-1)

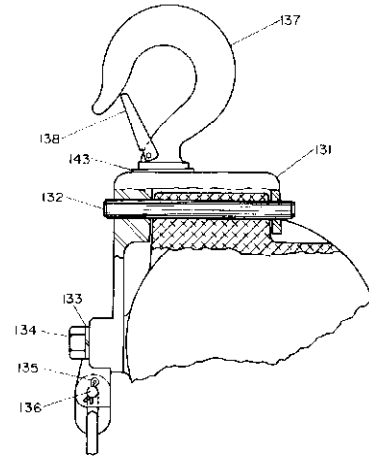

**Top Hook Assembly**

(Dwg. TPC441-1)

ITEM NO.	DESCRIPTION OF PART	TOTAL QTY.	PART NO.			
			STANDARD (1 t max)		SPARK RESISTANT (1/2 t max)	
			ML1000K and ML1000KS		ML500KR	
*	Bottom Hook Assembly	1	ML100K-A378	CA110-AR378		
*	Hook Assembly	1	ML1000K-KS377	ML500KR-K377 (Bronze)		
125	Hook Block	2	CE120-B378 (Aluminum)	CA110-BR378 (Aluminum)		
*	Nameplate	2	---	CA110SR-99		
*	Drive Screw	8	---	R4K-302-12		
• 126	<b>Bearing</b>	2	<b>OC9-593</b>			
127	Thread Inserts	3	CE120-38			
128	Thrust Washer	2	CE120-80			
129	Pocket Wheel	1	CE120-380			
130	Bolt	3	CE120-312			
*	Top Hook Assembly	1	ML1000K-K590	ML500KR-K590		
*	Hook Assembly	1	ML1000K-KS377	ML500KR-K377 (Bronze)		
131	Hook Yoke	1	ML1000K-590			
132	Pin	2	ML1000K-964			
133	Lockwasher	2	D02-321-10			
134	Bolt	2	PDA321-28			
• 135	<b>Cotter Pin</b>	2	<b>D02-524</b>			
• 136	<b>Pin</b>	1	<b>ML20-962A</b>			
	<b>Top or Bottom Hook Assembly</b>		<b>Standard Steel (1 t max)</b>	<b>Bronze (1 t max)</b>	<b>Bullard Burnaham (1 t max)</b>	<b>Copper Plated (1 t max)</b>
*	Hook Assembly	1	ML1000K-KS377	ML500KR-K377	CE120-KBB377	ML1000K-KCPS377
137	Hook	1	HRA20A-S377	CA-SR304	CE120-BB377X	ML1000K-CPS377
• 138	<b>Latch Kit</b>	1	<b>D01-S123</b>	<b>D01-S4055</b>	---	<b>D01-S123</b>
• 139	<b>Bearing</b>	1	<b>CE110-295</b>			
• 140	<b>Thrust Washer</b>	2	<b>CE120-596</b>			
141	Hook Nut	1	---	CA110-R305	CE120-BB377Y	---
• 142	<b>Hook Nut Pin</b>	1	---	<b>MLK-826</b>		
• 143	<b>Retainer Ring (Top Hook Only)</b>	1	<b>HRA20A-375</b>	---	---	<b>HRA20A-375</b>

• Recommended Spare

\* Not illustrated

# TROLLEY ASSEMBLY DRAWING

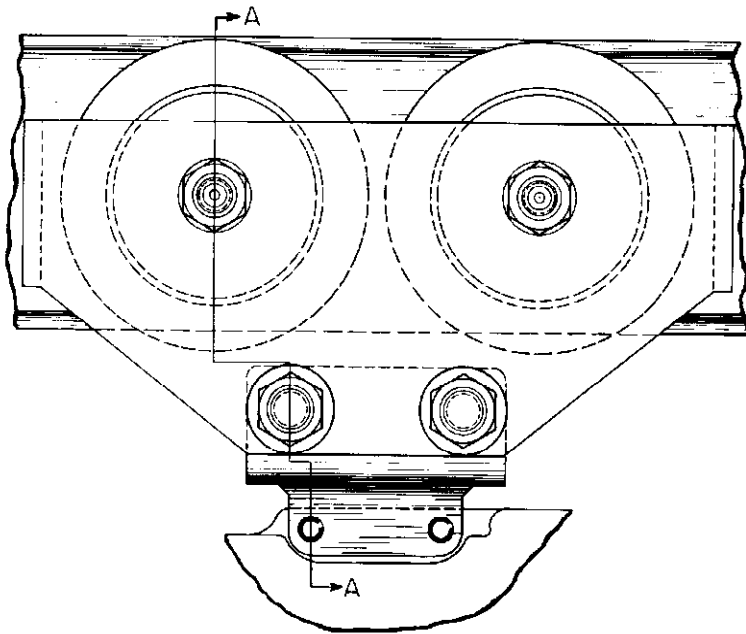

**Side View of Rigid Trolley**

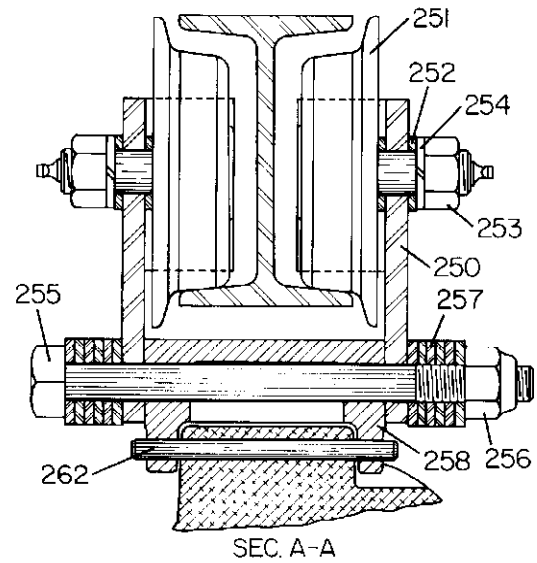

**End View of Rigid Trolley for ML250K, ML250KR, ML500K, ML500KS and ML250KS**

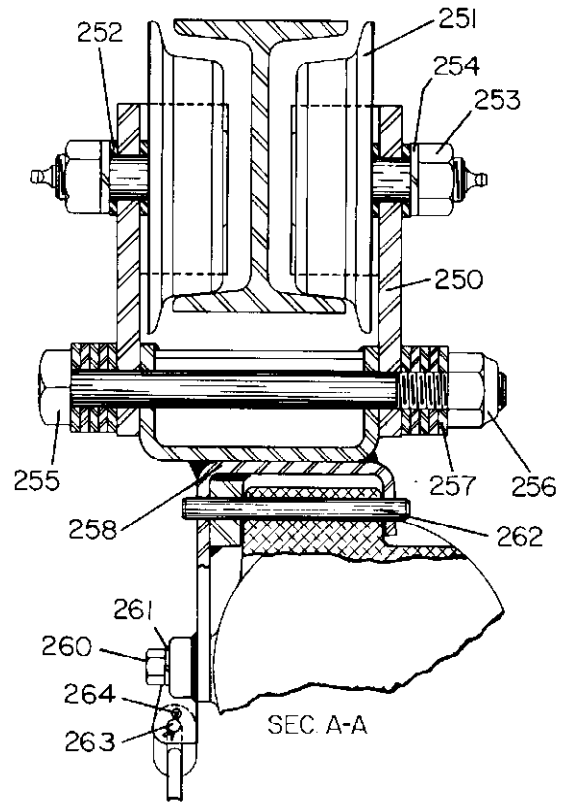

**End View of Rigid Trolley for ML1000K, ML500KR**

## NOTICE

1. Insert a minimum of one Trolley Bracket Spacer (257) between the head of the Trolley Bracket Bolt (255) and the Trolley Bracket (250) and a minimum of one Trolley Bracket Spacer between the Trolley Bolt Nut (256) and the Trolley Bracket.
2. Torque the Trolley Bolt Nuts (256) to 150 ft-lb (203 N.m ).

( Dwg. TPA825-2)

## TROLLEY ASSEMBLY PARTS LIST

ITEM NO.	DESCRIPTION OF PART	TOTAL QTY.	PART NO.
---	Rigid Trolley Kit	1	---
	for operation on I-beam having flanges 2.66 in. (68 mm) to 5.00 in. (127 mm) wide		---
	1/4 and 1/2 ton (3-1/8 in. dia. tapered tread wheels)		MLK-K430
	1/4 and 1/2 ton Spark Resistant (3-1/8 in. dia. tapered tread wheels)		MLK-KR430
	for operation on I-beam having flanges 3.00 in. (76 mm) to 5.00 in. (127 mm) wide		---
	1/4, 1/2 and 1 ton (4 in. dia. tapered tread wheels)		CE120 K430
	for operation on Flat-Tread Monorail having flanges 3.00 in. (76 mm) to 5.00 in. (127 mm) wide		---
	1/4, 1/2 and 1 ton (4 in. dia. flat tread wheels)		CE120-K430T
	1/4 and 1/2 ton Spark Resistant (4 in. dia. flat tread wheels)		CE120-KR430T
250	Trolley Side Plate	2	---
	for MLK-K430 and MLK-KR430		MLK-430
	for CE120-K430, CE120-K430T and CE120-KR430T		CE120-430
251	Trolley Wheel	4	---
	for MLK-K430 (3-1/8 in. dia. tapered)		MR10-691
	for MLK-KR430 (3-1/8 in. dia. tapered beryllium copper)		MR10-1691
	for CE120-K430 (4 in. dia. tapered)		MR20-691
	for CE120-K430T (4 in. dia. flat tread)		MR20-691T
252	Trolley Wheel Spacer	8	---
	for MLK-K430 and MLK-KR430		D10-807
	for all others		21-748
253	Trolley Wheel Shaft Nut	4	---
	for MLK-K430 and MLK-KR430		215-182
	for all others		DU-562
254	Trolley Wheel Shaft Lockwasher	4	---
	for MLK-K430 and MLK-KR430		D10-322-5
	for all others		D01-692
255	Trolley Bracket Bolt	2	D01-694-8
256	Trolley Bolt Nut	2	D01-341A
257	Trolley Bracket Spacer	28 (as required)	D01-442-1/6
---	Top Lug Kit	1	---
	for ML250K, ML250KR, ML500K, ML250KS and ML500KS		MLK-K425
	for ML500KR, ML100K and ML1000KS		ML1000K-K425
258	Top Lug	1	---
	for ML250K, ML250KR, ML500K, ML250KS and ML500KS		MR10-425
	for ML500KR, ML1000K and ML1000KS		ML20-425A
260	Top Lug Screw (for ML500KR, ML1000K and ML1000KS)	2	D10-312A
261	Lockwasher (for ML500KR, ML1000K and ML1000KS)	2	D02-321-10
262	Top Lug Pin	2	MR-964
263	Link Chain Anchor Pin (for ML500KR, ML1000K and ML1000KS)	1	ML20-962A
264	Link Chain Anchor Pin Cotter (for ML500KR, ML1000K and ML1000KS)	2	D02-524

## TROLLEY ASSEMBLY PARTS LIST

### PUSH TYPE HOOK SUSPENSION TROLLEYS

Hoist Capacity (tons)	Part Number		For use on Hoist Model	Wheel Diameter	Adjustable for Flange Widths
	Tapered Tread (I-Beam)	Flat Tread (WF-Beam)			
1/4 and 1/2	MR10-7927	---	ML250K, ML250KS, ML500K and ML500KS	3-1/8 in. (79 mm)	2.66 in. to 5.00 in. (68 mm to 127 mm)
	CE110-KR426	---	ML250KR and ML500KR		
	---	CE120-KR426T		4.0 in. (103 mm)	3.00 in. to 5.00 in. (76 mm to 127 mm)
1/4, 1/2 and 1	CE120-K426	CE120-K426T	All except Spark Resistant		

### PUSH TYPE RIGID MOUNT TROLLEYS (For Use Only With Lug Mounted Hoists)

Hoist Capacity (tons)	Part Number		For use on Hoist Model	Wheel Diameter	Adjustable for Flange Widths
	Tapered Tread (I-Beam)	Flat Tread (WF-Beam)			
1/4 and 1/2	MLK-K430	---	ML250K, ML250KS, ML500K and ML500KS	3-1/8 in. (79 mm)	2.66 in. to 5.00 in. (68 mm to 127 mm)
	MLK-KR430	---	ML250KR and ML500KR		
	---	CE120-KR430T		4.0 in. (103 mm)	3.00 in. to 5.00 in. (76 mm to 127 mm)
1/4, 1/2 and 1	CE120-K430	CE120-K430T	All except Spark Resistant		

### HOSE TROLLEYS

Part Number	American Standard I-Beam		Flange Width	
	in.	mm	in.	mm
D02-8888	3 - 12	76 - 305	2.33 - 5	29 - 127
D10-8888	12 and above	305 and above	5 - 8.75	127 - 222

#### Vane Motor Driven Trolleys

Refer to Installation and Maintenance Manual form P6609 for additional information.



# INSTALLATION INSTRUCTIONS FOR FABRIC CHAIN CONTAINER KITS

## ⚠ WARNING

- Disconnect the hoist from the Air Supply before installing a Chain Container Kit.

Refer to Dwgs. TPB605-2 and TPD580

1. Insert a Container Bolt (305) through the boss on the Hoist housing and into the Brackets (301 and 302). Retain the Container with the Bracket Bolt Nuts (304).

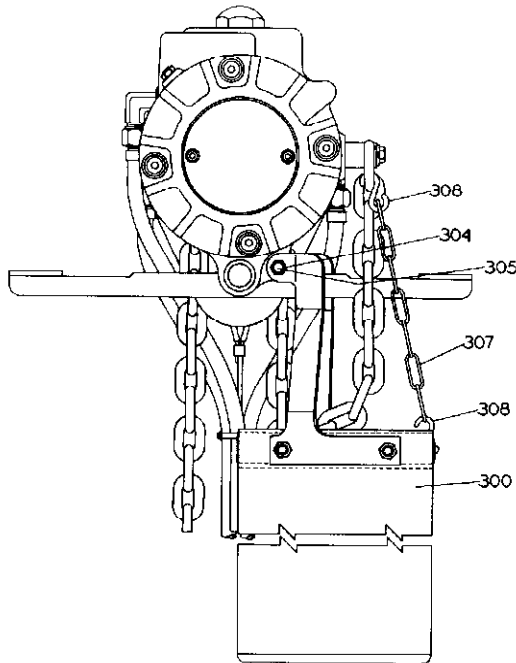

(Dwg. TPB605-2)

## NOTICE

- If the container is to be allowed to swing outward, tighten the Nuts to within one turn of being fully tight. This will allow the container to swing away from a load.

2. Apply the Balance Chain (307) to the Container and Hoist using the S-Hooks (308). Adjust the length of the Chain to prevent the load chain from rubbing on the Container.

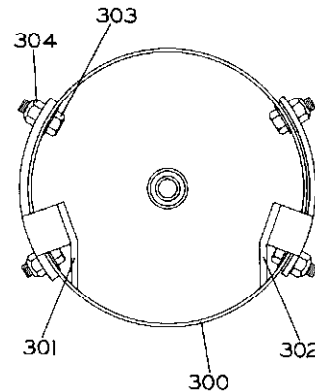

(Dwg. TPD580)  
TOP VIEW OF CHAIN CONTAINER FOR MLK HOIST

ITEM NO.	DESCRIPTION OF PART	TOTAL QTY.	PART NO.
---	Fabric Chain Container Kit	1	---
	for ML250K or ML500K Hoists with up to 17 ft lift or ML1000K Hoists with up to 9 ft lift		ML50K-K749-17
	for ML250K or ML500K Hoists with up to 45 ft lift or ML1000K Hoists with up to 23 ft lift		ML50K-K749-45
	for ML250K or ML500K Hoists with up to 80 ft lift or ML1000K Hoists with up to 40 ft lift		ML50K-K749-80
300	Fabric Chain Container	1	---
	for ML50K-K749-17		ML50K-749-17
	for ML50K-K749-45		ML50K-749-45
	for ML50K-K749-80	ML50K-749-80	
301	Left Bracket	1	ML50K-748
302	Right Bracket	1	ML50K-747
303	Bracket Bolt	4	R2N-103
304	Bracket Bolt Nut	6	ML50K-394
305	Chain Container Bolt	2	5080-638-4
307	Balance Chain	1	CA110-240-1/2
308	S-Hook	2	D02-421

## METAL CHAIN CONTAINER KITS

ITEM NO.	DESCRIPTION OF PART	TOTAL QTY.	PART NO.
---	Metal Chain Container Kit	1	---
	for ML250K or ML500K Hoists with up to 26 ft lift or ML1000K Hoists with up to 13 ft lift		ML20-K749A
	for ML250K or ML500K Hoists with up to 40 ft lift or ML1000K Hoists with up to 20 ft lift		ML20-K749-20
	for ML250K or ML500K Hoists with up to 80 ft lift or ML1000K Hoists with up to 40 ft lift		MLK-K750-80
300	Metal Chain Container	1	---
	for ML20-K749A (26 foot chain capacity)		order kit ML20-K749A
	for ML20-K749-20 (40 foot chain capacity)		order kit ML20-K749-20
	for MLK-K750-80 (80 foot chain capacity)		order kit MLK-K750-80
*	Screw	2	M0V010AA-634
*	Nut	2	MR-37

\* Not shown

## ACCESSORIES

### FILTERS, REGULATORS AND LUBRICATORS

Filter, Regulator and Lubricator Kit Part Number	Filter Part Number		Regulator Part Number	Lubricator Part Number		Size NPTF
	Polycarbonate Bowl	Metal Bowl		Polycarbonate Bowl	Metal Bowl	
C22-04-G00	F20-04-000	F20-04-G00	R20-04-G00	L20-04-000	L20-04-G00	1/2
C31-06-G00	F30-06-000	F30-06-G00	R20-06-G00	L30-06-000	L30-06-G00	3/4
C31-08-G00	F30-08-000	F30-08-G00	R30-08-G00	L30-08-000	L30-08-G00	1

Polycarbonate Bowls include a metal bowl guard

Metal Bowls include sight gauges

Description	Part No.
Yellow Touch-Up Paint	FAP-237Y
Chain Lubricant	LUBRI-Link

## REPAIR AND CONVERSION KITS

**Fabric Chain Container:** Includes Chain Container, Brackets and all hardware necessary for installation on a Hoist.

No. ML50K-K749-17 (03551066) for use on a single line Hoist with up to a 17 ft (5 m) lift and on a double line hoist with up to a 9 ft (2.7 m) lift.

No. ML50K-K749-45 (03551074) for use on a single line Hoist with up to a 45 ft (14 m) lift and on a double line Hoist with up to a 23 ft (7 m) lift.

**Metal Chain Containers:**

No. ML20-K749A for use on a single line Hoist with up to 26 ft (8 m) lift and on a double line Hoist with up to 13 ft (4 m) lift.

No. ML20-K749-20 for use on a single line Hoist with up to 40 ft (12 m) lift and on a double line Hoist with up to 20 ft (6 m) lift.

No. MLK-K750-80 for use on a single line Hoist with up to 80 ft (24 m) lift and on a double line Hoist with up to 40 ft (12 m) lift.

**Pendent Conversion Kit:** Includes all components necessary to convert a pull chain throttle Hoist to pendent control operation.

No. MLK-KL112A (03700507) for use on all MLK Hoists. Length of pendent must be specified when ordering. Pendent length is normally 5 ft (1.5 m) shorter than lift.

**Pull Chain Conversion Kit:** Includes all components necessary, except the pull chains, to convert a pendent throttle Hoist to pull chain control operation.

No. MLK-K415 (03700618) for use on all MLK Hoists. Order pull chains separately.

No. CA110-B240 (03457769) Pull Chain for use on standard MLK Hoists. Specify total length of two required pull chains.

No. D02-1413 (03170685) Pull Chain for use on spark resistant MLK Hoists. Specify total length of two required pull chains.

**Valve Chest Conversion Kit:** Includes all components necessary to convert Valve Chests used on Hoists with second letter of the Serial Number A through G or with second and third letters of the Serial Number HA, HB or HC to the same style Valve Chest used on Hoists with second letter of the Serial Number other than A through G or with second and third letters of the Serial Number other than HA, HB or HC.

No. MLK-K545B (03835519)

**Manual Brake Release Kit:** Includes all the components for a manual release brake and/or 200% brake capability.

No. MLK-K390 (03721685) for use on all MLK Hoists.

**Two and Three-Motor Pendants:**

No. HRA-A122B (03709177) Two-motor pendent less hose.

No. HRA-A132B (03709219) Three-motor pendent less hose.

**Two and Three-Motor Pendent and Hose Assembly:**

No. MLK-A122-10 (03611928) Two-motor pendent and hose assembly (5 ft. (1.5 m) pendent length).

No. MLK-AL122 (03622487) Two-motor pendent and hose assembly (Specify length of hose required).

No. MLK-A132-10 (03611936) Three-motor pendent and hose assembly (5 ft.(1.5 m) pendent length).

No. MLK-AL132 (03622495) Three-motor pendent and hose assembly (Specify length of hose required).

**Quick-Exhaust Valves:** Must be used on all Hoists with Pendent Control when hoses exceed 50 ft (15 m) in length and includes all fittings and clamps.

No. MLK-A939 (03619681) for all MLK Hoists.

**Cross Mount:**

No. ML500K-444 (03613023) for use on ML250K or ML500K.

No. ML1000K-444 (03613031) for use on ML1000K.

**Overhaul Gasket Kit:** Includes gaskets, O-rings and seals for ML250K, MI.250KR, MI.500K, MI.500KR and ML1000K Hoists.

No. MLK-K445 (03713740)

**Bullard-Burnham Gate Hooks:**

No. CE110-KBB377 (03504537) for ML250K and ML500K

No. CE120-KBB377 (03504545) for ML1000K

## REPAIR AND CONVERSION KITS (cont'd)

### **Precoiled Air Hose:**

- No. N12-25B     Hose Size 1/2 in. x 25 ft (13 mm x 8 m)
- No. N34-25B     Hose Size 3/4 in. x 25 ft (19 mm x 8 m)
- No. N34-50B     Hose Size 3/4 in. x 50 ft (19 mm x 15 m)

### **Vane and Spring Retrofit Kit:**

This kit will improve starting and low speed control on hoists not currently so equipped

No. MLK-KVSR1 Retrofit Kit includes illustrated parts 17, 31, 65, 93 and MLK-42 (7), MLK-43 (7).

### **Vane/Spring Kit**

No. MLK-K4243-7 Kit includes illustrated parts 69 (7) and 69A (7).

### **Vane Spring Packet**

No. MLK-43-7 Kit includes illustrated part 69A (7).

### **Down Valve Assembly**

No. MLK-K1102D Assembly includes illustrated part 17.

### **Valve Chest Kit:**

No. MLK-VCK1 Kit includes illustrated parts 18, 19 (2), 21 (4), 22 (2), 24 (2), 25 (2), 27 (2), 29 (2), 30 (2), 31 (2), 33 (2), 40 (2), 41, 42, 43 and 223.

### **Brake Kit:**

No. MLK-ABK1 Kit includes illustrated parts 95 (2), 97 (3) 100 and 101.

### **Chain Wheel Kit:**

No. MLK-CWK1 Kit includes illustrated parts 76, 77, 78, 79, 80 and non-illustrated part ML-741C.

## PARTS ORDERING INFORMATION

Your Hoist is designed and constructed to provide long, trouble-free service. In time it may become necessary to order and install new parts to replace those that have been subjected to wear.

The use of other than **Ingersoll-Rand Material Handling** replacement parts may result in decreased Hoist performance, and may, at the company's option invalidate the warranty. For prompt service and genuine **Ingersoll-Rand Material Handling** parts, provide your nearest Distributor with the following:

1. Complete hoist model number and serial number as it appears on the nameplate.
2. Part number and part description as shown in this manual.
3. Quantity required.

The serial number label is located on the hoist housing.



The model number label is located on the hoist housing.



For your convenience and future reference it is recommended that the following information be recorded.

Hoist Model Number \_\_\_\_\_

Hoist Serial Number \_\_\_\_\_

Date Purchased \_\_\_\_\_

### Return Goods Policy

If it becomes necessary to return the complete Hoist or certain parts to the factory, contact the Distributor from whom you purchased the Hoist, or the nearest **Ingersoll-Rand** Distributor in your locality.

**Ingersoll-Rand** will not accept any returned goods for warranty or service work unless prior arrangements have been made and written authorization has been provided from the location where the goods were purchased.

### NOTICE

• **Continuing improvement and advancement of design may cause changes to this hoist which are not included in this manual. Manuals are periodically revised to incorporate changes. Always check the manual edition number on the front cover for the latest issue.**

When the life of the hoist has expired, it is recommended that the hoist be disassembled, degreased and parts separated as to materials so that they may be recycled.

For additional information contact:  
**Ingersoll-Rand Material Handling**  
2724 Sixth Avenue South  
Seattle, Wa. 98124 USA  
Phone: (206) 624-0466  
Fax: (206) 624-6265

or

**Ingersoll-Rand International Sales**  
111, avenue Roger Salengro  
59450 Sin Le Noble, France  
Phone: (33) 27-93-08-08  
Fax: (33) 27-93-08-00

### NOTICE

• **Mineral based oils can be recycled, however, some oils such as glycols may be extremely toxic and must be identified and disposed of in accordance with local, state and national regulations.**

## HOIST AND WINCH LIMITED WARRANTY

Ingersoll-Rand Company (I-R) warrants to the original user its Hoists and Winches (Products) to be free of defects in material and workmanship for a period of one year from the date of purchase. I-R will repair, without cost, any Product found to be defective, including parts and labor charges, or at its option, will replace such Products or refund the purchase price less a reasonable allowance for depreciation, in exchange for the Product. Repairs or replacements are warranted for the remainder of the original warranty period.

If any Product proves defective within its original one year warranty period, it should be returned to any Authorized Hoist and Winch Service Distributor, transportation prepaid with proof of purchase or warranty card.

This warranty does not apply to Products which I-R has determined to have been misused or abused, improperly maintained by the user, or where the malfunction or defect can be attributed to the use of non-genuine I-R parts.

**I-R makes no other warranty, and all implied warranties including any warranty of merchantability or fitness for a particular purpose are limited to the duration of the expressed warranty period as set forth above. I-R's maximum liability is limited to the purchase price of the Product and in no event shall I-R be liable for any consequential, indirect, incidental, or special damages of any nature rising from the sale or use of the Product, whether based on contract, tort, or otherwise.**

**Note:** Some states do not allow limitations on incidental or consequential damages or how long an implied warranty lasts so that the above limitations may not apply to you.

This warranty gives you specific legal rights and you may also have other rights which may vary from state to state.

## IMPORTANT NOTICE

It is our policy to promote safe delivery of all orders.

This shipment has been thoroughly checked, packed and inspected before leaving our plant and receipt for it in good condition has been received from the carrier. Any loss or damage which occurs to this shipment while enroute is not due to any action or conduct of the manufacturer.

### **VISIBLE LOSS OR DAMAGE**

If any of the goods called for on the bill of lading or express receipt are damaged or the quantity is short, do not accept them until the freight or express agent makes an appropriate notation on your freight bill or express receipt.

### **CONCEALED LOSS OR DAMAGE**

When a shipment has been delivered to you in apparent good condition, but upon opening the

crate or container, loss or damage has taken place while in transit, notify the carrier's agent immediately.

### **DAMAGE CLAIMS**

You must file claims for damage with the carrier. It is the transportation company's responsibility to reimburse you for repair or replacement of goods damaged in shipment. Claims for loss or damage in shipment must not be deducted from the Ingersoll-Rand invoice, nor should payment of Ingersoll-Rand invoice be withheld awaiting adjustment of such claims as the carrier guarantees safe delivery.

You may return products damaged in shipment to us for repair, which services will be for your account and form your basis for claim against the carrier.

## United States Office Locations

### For Order Entry and Order Status

**Ingersoll-Rand  
Distribution Center**  
P.O. Box 618  
510 Hester Drive  
White House, TN 37188  
Phone: (615) 672-0321  
Telex: 786573  
Fax: (615) 672-0801

### For Technical Support

**Ingersoll-Rand  
Material Handling**  
P.O. Box 24046  
2724 Sixth Avenue South  
Seattle, WA 98124-0046  
Phone: (206) 624-0466  
Telex: 786573  
Fax: (206) 624-6265

### Regional Sales Offices

**Atlanta, GA**  
111 Ingersoll-Rand Drive  
Chamblee, GA 30341  
Phone: (404) 936-6230

**Detroit, MI**  
23192 Commerce Drive  
Farmington Hills, MI 48335  
Phone: (313) 476-6677  
Fax: (313) 476-6670

**Houston, TX**  
Suite 150  
2500 East T.C. Jester  
Houston, TX 77008  
Phone: (713) 864-3700

**Los Angeles, CA**  
11909 E. Telegraph Road  
P.O. Box 2525  
Santa Fe Springs, CA 90670  
Phone: (310) 948-4189  
Fax: (310) 948-1828

**Milwaukee, WI**  
12311 W. Silver Spring Dr.  
Milwaukee, WI 53225  
Phone: (414) 461-0973

**Philadelphia, PA**  
P.O. Box 425  
900 E. 8th Ave., Suite 103  
King of Prussia, PA 19406  
Phone: (215) 337-5930

## International

Offices and distributors in principal cities throughout the world. Contact the nearest **Ingersoll-Rand** office for the name and address of the distributor in your country or write/ fax to:

**Ingersoll-Rand  
Material Handling**  
P.O. Box 24046  
2724 Sixth Avenue South  
Seattle, WA 98124-0046  
USA  
Phone: (206) 624-0466  
Telex: 786573  
Fax: (206) 624-6265

**Canada  
National Sales Office  
Regional Warehouse  
Toronto, Ontario**  
51 Worcester Road  
Rexdale, Ontario  
M9W 4K2  
Phone: (416) 675-5611  
Fax: (416) 675-6920  
Order Desk  
Fax: (416) 674-6549

### Regional Sales Offices

**Calgary, Alberta**  
44 Harley Road S.E.  
Calgary, Alberta  
T2V 3K3  
Phone: (403) 252-4180  
Fax: (403) 252-4462

**Edmonton, Alberta**  
1430 Weber Center  
5555 Calgary Trail N.W.  
Edmonton, Alberta  
T6H 5G8  
Phone: (403) 438-5039  
Fax: (403) 437-3145

**Montreal, Quebec**  
3501 St. Charles Blvd.  
Kirkland, Quebec  
H9H 4S3  
Phone: (514) 695-9040  
Fax: (514) 695-0963

**British Columbia**  
201-6351 Westminster Hwy  
Richmond, B. C.  
V7C 5C7  
Phone: (604) 278-0459  
Fax: (604) 278-1254

### Latin America Operations Ingersoll-Rand Production Equipment Group

730 N.W. 107 Avenue  
Suite 300, Miami, FL  
33172-3107  
Phone: (305) 559-0500  
Telex: 441617TLS UI  
Fax: (305) 559-7505

### Europe, Middle East and Africa

**Ingersoll-Rand  
Material Handling  
Samiia, Douai Operations**  
111, avenue Roger Salengro  
59450 Sin Le Noble, France  
Phone: (33) 27-93-08-08  
Fax: (33) 27-93-08-00

### Asia Pacific Operations Ingersoll-Rand (Japan) Ltd.

Kawa Bldg. No. 17  
2-7 Nishi-Azabu 1-Chrome  
Minato-ku, Tokyo 106 Japan  
Phone: (03) 3403-0641/7  
Fax: 81 3 3401-2409

### Russia Ingersoll-Rand Company

World Trade Center  
Office 1101  
Krasnopresnenskaya Nab. 12  
Moscow, Russia 123610