

# OPERATOR'S MANUAL

# PD03P-X-X

INCLUDING: OPERATION, INSTALLATION & MAINTENANCE

RELEASED: 12-17-05

REVISED: 12-21-06

(REV. 02)

## 3/8" DIAPHRAGM PUMP 1:1 RATIO, NON-METALLIC



**READ THIS MANUAL CAREFULLY BEFORE INSTALLING,  
OPERATING OR SERVICING THIS EQUIPMENT.**

It is the responsibility of the employer to place this information in the hands of the operator. Keep for future reference.

### SERVICE KITS

Refer to Model Description Chart to match the pump material options.  
637428 for air section repair (see page 6).  
637429-XX for fluid section repair (see page 4).

### PUMP DATA

<b>Models</b> .....	see Model Description Chart for "-XXX".
<b>Pump Type</b> .....	Air Operated Double Diaphragm.
<b>Material</b> .....	see Model Description Chart.
<b>Weight</b> ...	PD03P-XDS-XXX ..... 4.16 lbs (1.89 kgs)
	PD03P-XES-XXX ..... 4.26 lbs (1.93 kgs)
	PD03P-XKS-XXX ..... 4.50 lbs (2.04 kgs)
	PD03P-XLS-XXX ..... 4.62 lbs (2.10 kgs)
	PD03P-XPS-XXX ..... 3.44 lbs (1.56 kgs)
	PD03P-XRS-XXX ..... 3.50 lbs (1.59 kgs)
<b>Maximum Air Inlet Pressure</b> .....	100 p.s.i.g. (6.9 bar)
<b>Maximum Material Inlet Pressure</b> .....	10 p.s.i.g. (0.69 bar)
<b>Maximum Outlet Pressure</b> .....	100 p.s.i.g. (6.9 bar)
<b>Air Consumption @ 40 p.s.i.</b> .....	1 c.f.m. / gallon (approx.)
<b>Maximum Flow Rate (flooded inlet)</b> .....	10.6 g.p.m. (40.1 l.p.m.)
<b>Displacement / Cycle @ 100 p.s.i.</b> .....	0.022 gallons (0.083 lit.)
<b>Maximum Particle Size</b> .....	1/16" dia. (1.6 mm)
<b>Maximum Temperature Limits (diaphragm / ball / seat material)</b>	
Acetal .....	10° to 180° F (-12 to 82° C)
Hytrel® .....	-20° to 150° F (-29° to 66° C)
Polypropylene .....	35° to 150° F (2° to 66° C)
Kynar® PVDF .....	10° to 200° F (-12 to 93° C)
Santoprene® .....	-40° to 225° F (-40° to 107° C)
Teflon® PTFE .....	40° to 225° F (4° to 107° C)
Viton® .....	-40° to 350° F (-40° to 177° C)
<b>Groundable Models</b> .....	PD03P-XDS-XXX PD03P-XES-XXX
<b>Dimensional Data</b> .....	see page 8
<b>Noise Level @ 70 p.s.i., 60 c.p.m.</b> .....	72.7 db(A)①

① The pump sound pressure levels published here have been updated to an Equivalent Continuous Sound Level ( $L_{Aeq}$ ) to meet the intent of ANSI S1.13-1971, CAGI-PNEU-ROP S5.1 using four microphone locations.

**NOTICE: All possible options are shown in the chart however certain combinations may not be recommended, consult a representative or the factory if you have questions concerning availability.**

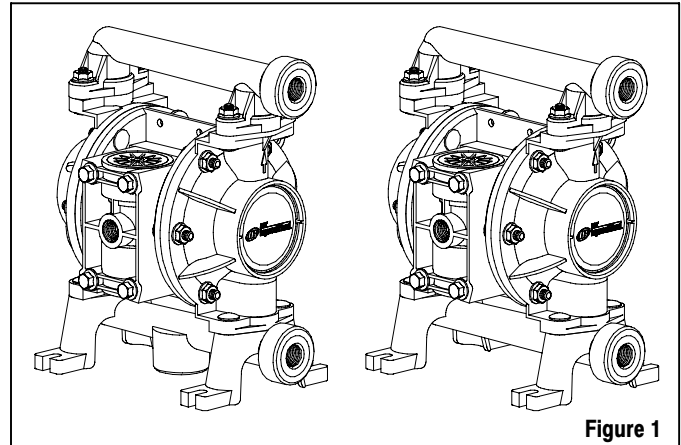

Figure 1

### MODEL DESCRIPTION CHART

PD03 P - X X S - X X X	
<b>Center Section Material</b> P - Polypropylene	P
<b>Fluid Connection</b> A - 3/8 - 18 N.P.T.F. - 1 B - Rp 3/8 (3/8 - 19 BSP)	A, B
<b>Fluid Caps / Manifold Material</b> D - Groundable Acetal (single port) E - Groundable Acetal (multiple port) K - Kynar PVDF (single port) L - Kynar PVDF (multiple port) P - Polypropylene (single port) R - Polypropylene (multiple port)	D, E, K, L, P, R
<b>Hardware Material</b> S - Stainless Steel	S
<b>Seat Material</b> D - Acetal                      P - Polypropylene K - Kynar PVDF                S - Stainless Steel	D, K, P, S
<b>Ball Material</b> A - Santoprene                T - Teflon PTFE C - Hytrel                        V - Viton S - Stainless Steel	A, C, S, T, V
<b>Diaphragm Material</b> A - Santoprene                T - Teflon PTFE / Santoprene C - Hytrel                        V - Viton	A, C, T, V
<b>FLUID SECTION SERVICE KIT SELECTION</b> PD03P - ARS - S X X	
Example: Model # PD03P-ARS-SAA                      637429 - X X	
Fluid Section Service Kit # 637429-AA                      Ball                      Diaphragm	

## OPERATING AND SAFETY PRECAUTIONS

READ, UNDERSTAND AND FOLLOW THIS INFORMATION TO AVOID INJURY AND PROPERTY DAMAGE.

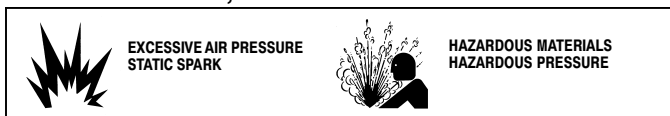

**⚠ WARNING** EXCESSIVE AIR PRESSURE. Can cause personal injury, pump damage or property damage.

- Do not exceed the maximum inlet air pressure as stated on the pump model plate.
- Be sure material hoses and other components are able to withstand fluid pressures developed by this pump. Check all hoses for damage or wear. Be certain dispensing device is clean and in proper working condition.

**⚠ WARNING** STATIC SPARK. Can cause explosion resulting in severe injury or death. Ground pump and pumping system.

- PD03P-XDS-XXX and PD03P-XES-XXX Groundable Acetal pumps: Use the pump ground lug provided. Connect to a 12 ga. (minimum) wire (kit is included) to a good earth ground source.
- Sparks can ignite flammable material and vapors.
- The pumping system and object being sprayed must be grounded when it is pumping, flushing, recirculating or spraying flammable materials such as paints, solvents, lacquers, etc. or used in a location where surrounding atmosphere is conducive to spontaneous combustion. Ground the dispensing valve or device, containers, hoses and any object to which material is being pumped.
- Secure pump, connections and all contact points to avoid vibration and generation of contact or static spark.
- Consult local building codes and electrical codes for specific grounding requirements.
- After grounding, periodically verify continuity of electrical path to ground. Test with an ohmmeter from each component (e.g., hoses, pump, clamps, container, spray gun, etc.) to ground to insure continuity. Ohmmeter should show 0.1 ohms or less.
- Submerge the outlet hose end, dispensing valve or device in the material being dispensed if possible. (Avoid free streaming of material being dispensed.)
- Use hoses incorporating a static wire.
- Use proper ventilation.
- Keep inflammables away from heat, open flames and sparks.
- Keep containers closed when not in use.

**⚠ WARNING** Pump exhaust may contain contaminants. Can cause severe injury. Pipe exhaust away from work area and personnel.

- In the event of a diaphragm rupture material can be forced out of the air exhaust muffler.
- Pipe the exhaust to a safe remote location when pumping hazardous or inflammable materials.
- Use a grounded 3/8" minimum i.d. hose between the pump and the muffler.

**⚠ WARNING** HAZARDOUS PRESSURE. Can result in serious injury or property damage. Do not service or clean pump, hoses or dispensing valve while the system is pressurized.

- Disconnect air supply line and relieve pressure from the system by opening dispensing valve or device and / or carefully and slowly loosening and removing outlet hose or piping from pump.

**⚠ WARNING** HAZARDOUS MATERIALS. Can cause serious injury or property damage. Do not attempt to return a pump to the factory or service center that contains hazardous material.

Safe handling practices must comply with local and national laws and safety code requirements.

- Obtain Material Safety Data Sheets on all materials from the supplier for proper handling instructions.

**⚠ WARNING** EXPLOSION HAZARD. Models containing aluminum wetted parts cannot be used with 1,1,1-trichloroethane, methylene chloride or other halogenated hydrocarbon solvents which may react and explode.

- Check pump motor section, fluid caps, manifolds and all wetted parts to assure compatibility before using with solvents of this type.

**⚠ CAUTION** Verify the chemical compatibility of the pump wetted parts and the substance being pumped, flushed or recirculated. Chemical compatibility may change with temperature and concentration of the chemical(s) within the substances being pumped, flushed or circulated. For specific fluid compatibility, consult the chemical manufacturer.

**⚠ CAUTION** Maximum temperatures are based on mechanical stress only. Certain chemicals will significantly reduce maximum safe operating temperature. Consult the chemical manufacturer for chemical compatibility and temperature limits. Refer to Pump Data on page 1 of this manual.

**⚠ CAUTION** Be certain all operators of this equipment have been trained for safe working practices, understand it's limitations, and wear safety goggles / equipment when required.

**⚠ CAUTION** Do not use the pump for the structural support of the piping system. Be certain the system components are properly supported to prevent stress on the pump parts.

- Suction and discharge connections should be flexible connections (such as hose), not rigid piped, and should be compatible with the substance being pumped.

**⚠ CAUTION** Prevent unnecessary damage to the pump. Do not allow pump to operate when out of material for long periods of time.

- Disconnect air line from pump when system sits idle for long periods of time.

**⚠ CAUTION** Use only genuine ARO® replacement parts to assure compatible pressure rating and longest service life.

**NOTICE** Install the pump in the vertical position. The pump may not prime properly if the balls do not check by gravity upon start-up.

**NOTICE** Re-torque all fasteners before operation. Creep of housing and gasket materials may cause fasteners to loosen. Re-torque all fasteners to insure against fluid or air leakage.

**NOTICE** Replacement warning labels are available upon request: "Static Spark" pn \ 93616-1, "Diaphragm Rupture" pn \ 93122.

**⚠ WARNING** = Hazards or unsafe practices which could result in severe personal injury, death or substantial property damage.

**⚠ CAUTION** = Hazards or unsafe practices which could result in minor personal injury, product or property damage.

**NOTICE** = Important installation, operation or maintenance information.

---

## GENERAL DESCRIPTION

---

The ARO diaphragm pump offers high volume delivery even at low air pressure and a broad range of material compatibility options available. Refer to the model and option chart. ARO pumps feature stall resistant design, modular air motor / fluid sections.

Air operated double diaphragm pumps utilize a pressure differential in the air chambers to alternately create suction and positive fluid pressure in the fluid chambers, ball checks insure a positive flow of fluid.

Pump cycling will begin as air pressure is applied and it will continue to pump and keep up with the demand. It will build and maintain line pressure and will stop cycling once maximum line pressure is reached (dispensing device closed) and will resume pumping as needed.

---

## AIR AND LUBE REQUIREMENTS

---

**⚠ WARNING EXCESSIVE AIR PRESSURE. Can cause pump damage, personal injury or property damage.**

- A filter capable of filtering out particles larger than 50 microns should be used on the air supply. There is no lubrication required other than the “O” ring lubricant which is applied during assembly or repair.
- If lubricated air is present, make sure that it is compatible with the “O” rings and seals in the air motor section of the pump.

---

## OPERATING INSTRUCTIONS

---

- Always flush the pump with a solvent compatible with the material

being pumped if the material being pumped is subject to “setting up” when not in use for a period of time.

- Disconnect the air supply from the pump if it is to be inactive for a few hours.
- The outlet material volume is governed not only by the air supply but also by the material supply available at the inlet. The material supply tubing should not be too small or restrictive. Be sure not to use hose which might collapse.
- When the diaphragm pump is used in a forced-feed (flooded inlet) situation, it is recommended that a “Check Valve” be installed at the air inlet.
- Secure the diaphragm pump legs to a suitable surface to insure against damage by vibration.

---

## MAINTENANCE

---

- Certain ARO “Smart Parts” are indicated which should be available for fast repair and reduction of down time.
- Provide a clean work surface to protect sensitive internal moving parts from contamination from dirt and foreign matter during service disassembly and reassembly.
- Keep good records of service activity and include pump in preventive maintenance program.
- Service Kits are available to service two separate Diaphragm Pump functions: 1. AIR SECTION, 2. FLUID SECTION. The Fluid Section is divided further to match typical active MATERIAL OPTIONS.

---

## TYPICAL CROSS SECTION

---

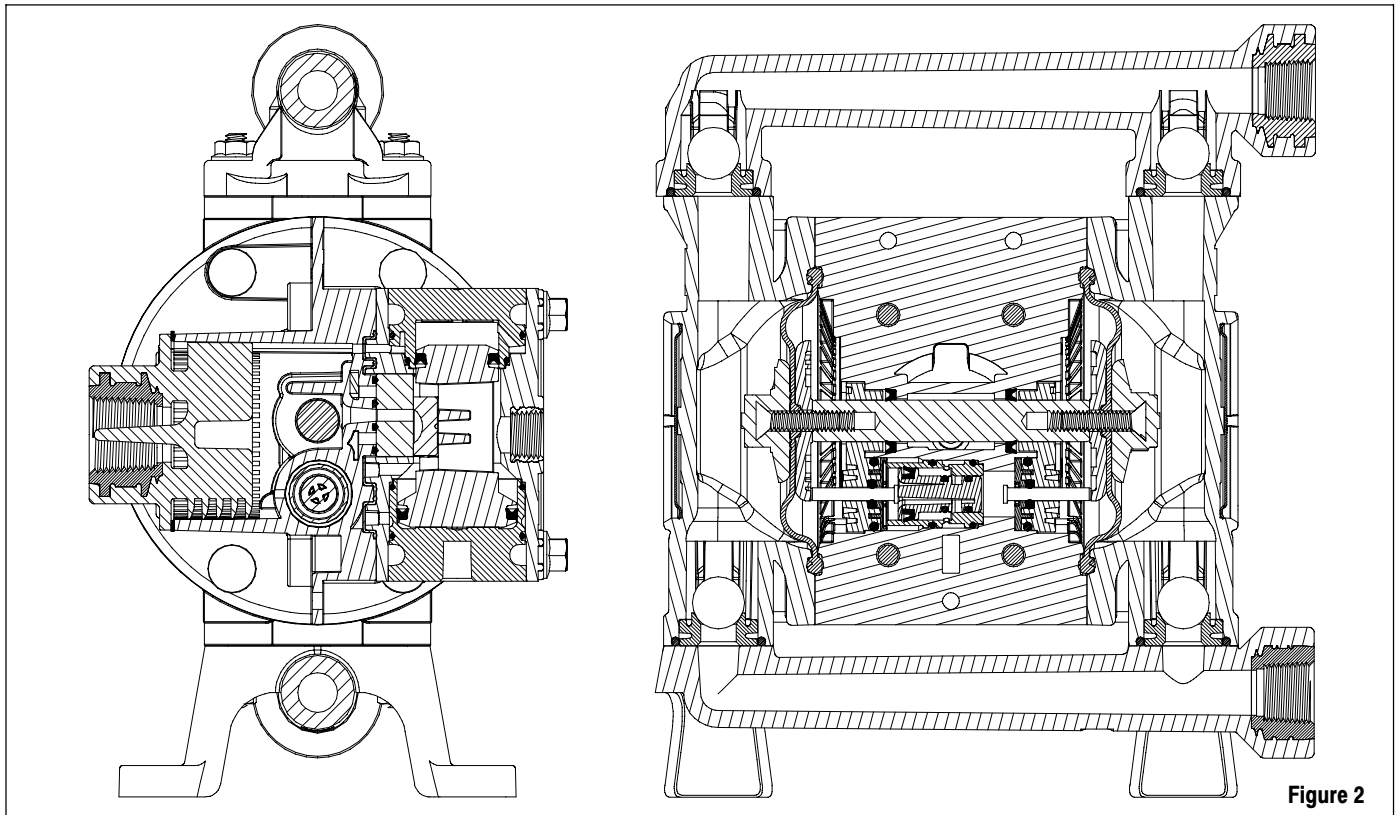

Figure 2

## PARTS LIST / PD03P-X-X FLUID SECTION

★ 637429-XX FLUID SECTION SERVICE KITS include: Balls (see BALL OPTION, refer to -XX in chart below), Diaphragms (See DIAPHRAGM OPTION, refer to -XX in chart below) and item 19 (listed below), plus items 144, 174 and 94276 Lubriplate® grease (page 6).

SEAT OPTIONS PD03P-XXS-XXX				BALL OPTIONS PD03P-XXS-XXX			
“21”				★ “22” (5/8” o.d.)			
-XXX	Seat	Qty	[Mtl]	-XXX	Ball	Qty	[Mtl]
-DXX	96580-2	(4)	[D]	-XAX	96481-A	(4)	[Sp]
-KXX	96580-3	(4)	[K]	-XCX	96481-C	(4)	[H]
-PXX	96580-1	(4)	[P]	-XVX	96481-3	(4)	[V]
-SXX	96537	(4)	[SS]				

MATERIAL CODE	
[A]	Aluminum
[B]	Nitrile
[D]	Acetal
[E]	E.P.R.
[GA]	Groundable Acetal
[GFN]	Glass Filled Nylon
[H]	Hytrel
[K]	Kynar PVDF
[P]	Polypropylene
[PPG]	Glass Filled Polypropylene
[Sp]	Santoprene
[SS]	Stainless Steel
[T]	Teflon PTFE
[V]	Viton

DIAPHRAGM OPTIONS PD03P-XXS-XXX										
-XXX	★ SERVICE KIT -XX = (Ball) -XX = (Diaphragm)	★ “7”			★ “8”			★ “19”		
		Diaphragm	Qty	[Mtl]	Diaphragm	Qty	[Mtl]	“O” Ring (3/32” x 1-1/8” o.d.)	Qty	[Mtl]
-XXA	637429-XA	96533-A	(2)	[Sp]	-----	---	---	93761	(4)	[E]
-XXC	637429-XC	96533-C	(2)	[H]	-----	---	---	Y325-119	(4)	[B]
-XXT	637429-XT	96538	(2)	[T]	96533-A	(2)	[Sp]	96514	(4)	[T]
-XXV	637429-XV	96558	(2)	[V]	-----	---	---	Y327-119	(4)	[V]

MANIFOLD / FLUID CAP OPTIONS PD03P-XXS-XXX														
Item	Description (size)	Qty	Polypropylene				Kynar PVDF				Groundable Acetal			
			Part No.	[Mtl]	Part No.	[Mtl]	Part No.	[Mtl]	Part No.	[Mtl]	Part No.	[Mtl]	Part No.	[Mtl]
□ 6	Diaphragm Nut (1/4” - 20)	(2)	93810-7	[P]	93810-7	[P]	93810-3	[K]	93810-3	[K]	93810-2	[D]	93810-2	[D]
15	Fluid Cap	(2)	96460-1	[P]	96460-1	[P]	96460-3	[K]	96460-3	[K]	96460-2	[GA]	96460-2	[GA]
43	Ground Strap	(1)	-----	---	-----	---	-----	---	-----	---	92956-1	[SS]	92956-1	[SS]
57	Ground Kit Assembly (not shown)	(1)	-----	---	-----	---	-----	---	-----	---	66885-1		66885-1	
60	Inlet Manifold (N.P.T.F.)	(1)	96468-1	[P]	96468-7	[P]	96468-3	[K]	96468-9	[K]	96468-2	[GA]	96468-8	[GA]
	(BSP)	(1)	96468-4	[P]	96468-10	[P]	96468-6	[K]	96468-12	[K]	96468-5	[GA]	96468-11	[GA]
61	Outlet Manifold (N.P.T.F.)	(1)	96469-1	[P]	96469-1	[P]	96469-3	[K]	96469-3	[K]	96469-2	[GA]	96469-2	[GA]
	(BSP)	(1)	96469-4	[P]	96469-4	[P]	96469-6	[K]	96469-6	[K]	96469-5	[GA]	96469-5	[GA]
63	Pipe Plug (N.P.T.F.)	(1)	-----	---	94478-1	[PPG]	-----	---	94478-3	[K]	-----	---	94478-2	[D]
	(BSP)	(1)	-----	---	96559-1	[PPG]	-----	---	96559-3	[K]	-----	---	96559-2	[D]

COMMON PARTS									
Item	Description (size)	Qty	Part No.	[Mtl]	Item	Description (size)	Qty	Part No.	[Mtl]
□ 1	Connecting Rod	(1)	96532	[SS]	27	Bolt (1/4” - 20 x 1-1/8”)	(12)	96471	[SS]
5	Diaphragm Washer	(2)	96556	[GFN]	29	Nut (1/4” - 20)	(20)	93828	[SS]
26	Bolt (1/4” - 20 x 1-1/8”)	(8)	96471	[SS]	77	Logo Plate	(2)	93264	[A]

DUAL INLET / DUAL OUTLET KITS 637442-X														
Item	Description (size)	Qty	Polypropylene				Kynar PVDF				Groundable Acetal			
			Part No.	[Mtl]	Part No.	[Mtl]	Part No.	[Mtl]	Part No.	[Mtl]	Part No.	[Mtl]	Part No.	[Mtl]
17	Dual Outlet Manifold	(2)	96520-1	[P]	96520-4	[P]	96520-3	[K]	96520-6	[K]	96520-2	[GA]	96520-5	[GA]
18	Dual Inlet Manifold	(2)	96519-1	[P]	96519-4	[P]	96519-3	[K]	96519-6	[K]	96519-2	[GA]	96519-5	[GA]
19	“O” Ring (3/32” x 1-1/8” o.d.)	(4)	96514	[T]	96514	[T]	96514	[T]	96514	[T]	96514	[T]	96514	[T]

□ “Smart Parts” keep these items on hand in addition to the Service Kits for fast repair and reduction of down time.

# PARTS LIST / PD03P-X-X FLUID SECTION

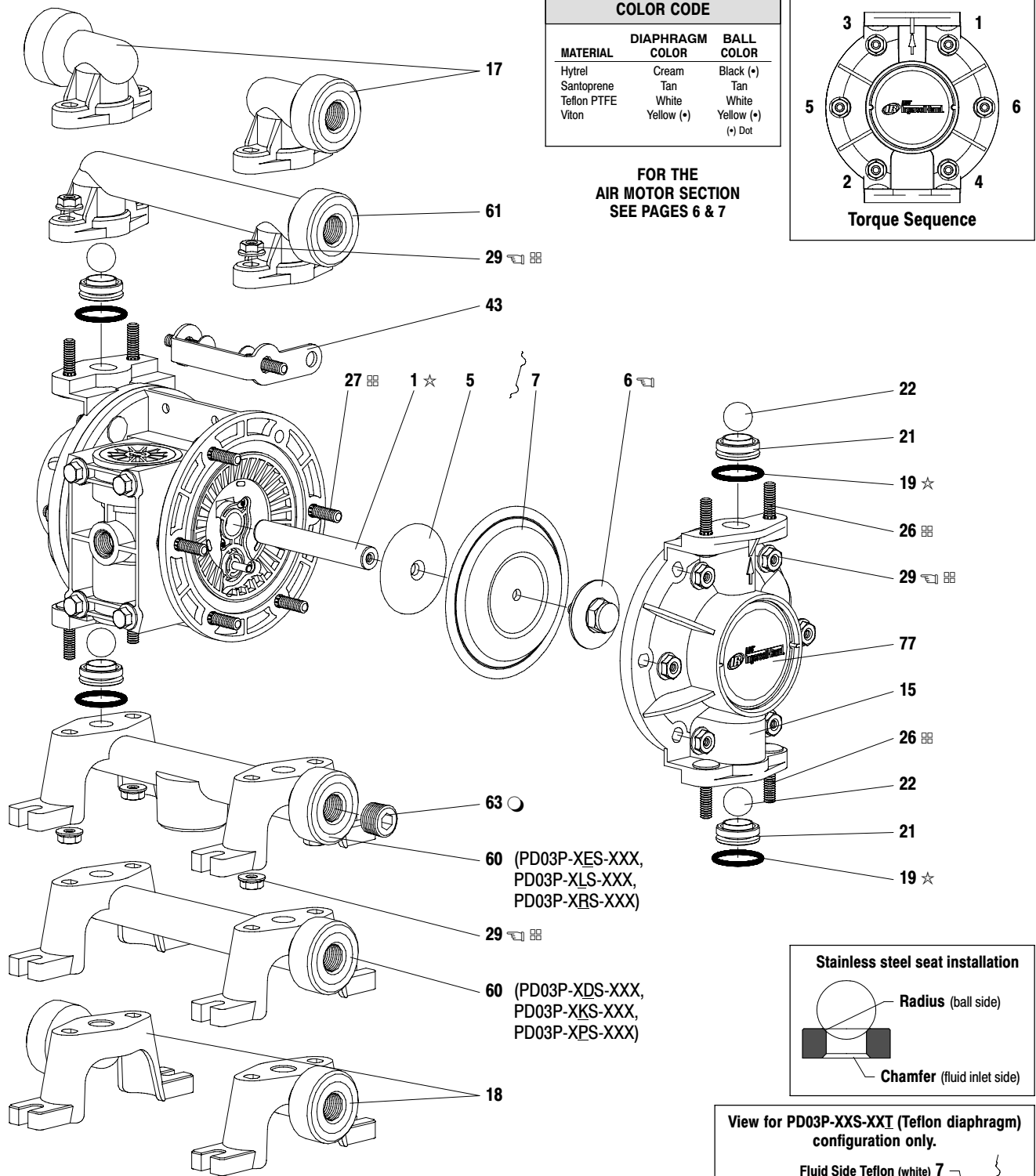

COLOR CODE		
MATERIAL	DIAPHRAGM COLOR	BALL COLOR
Hytrel	Cream	Black (+)
Santoprene	Tan	Tan
Teflon PTFE	White	White
Viton	Yellow (+)	Yellow (+)
		(+) Dot

FOR THE AIR MOTOR SECTION  
SEE PAGES 6 & 7

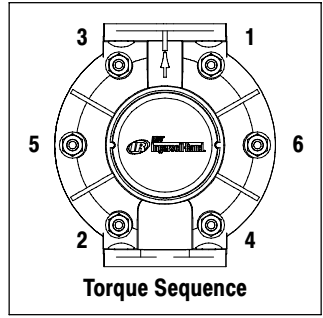
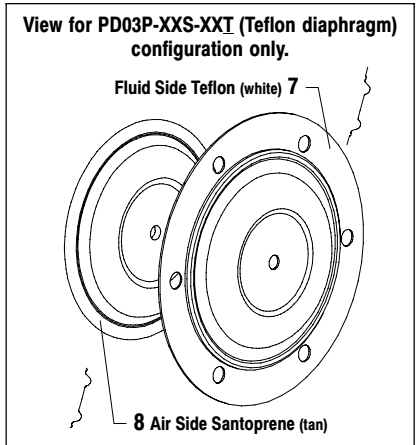

Figure 3

**TORQUE REQUIREMENTS**  
NOTE: DO NOT OVERTIGHTEN FASTENERS  
(6) Diaphragm nut 60 - 70 in. lbs (6.8 - 7.9 Nm).  
(29) Nut 50 - 60 in. lbs (5.6 - 6.8 Nm), / alternately and evenly, then re-torque after initial run-in.

**LUBRICATION / SEALANTS**

- Apply pipe sealant to threads.
- ☆ Apply Lubriplate (94276) to all "O" rings, "U" cups and mating parts.
- ☒ Apply anti-seize compound to threads and bolt and nut flange heads which contact pump case when using stainless steel fasteners.



## PARTS LIST / PD03P-X-X AIR MOTOR SECTION

✓ Indicates parts included in 637428 Air Section Repair Kit.

Item	Description (size)	Qty	Part No.	[MTI]
101	Center Body	(1)	96466	[PPG]
103R	Cover (right side)	(1)	96488	[D]
103L	Cover (left side)	(1)	96489	[D]
107	Plug, Small	(1)	96353	[D]
111	Major Valve Spool	(1)	95919	[D]
118	Actuator Pin	(2)	94874-1	[SS]
121	Washer	(2)	96092	[D]
123	Screw (#4 - 20 x 1/2")	(12)	96093	[SS]
129	Muffler Baffle	(1)	96542	[P]
130	Gasket	(1)	96531	[SY]
✓ 132	Air Manifold Gasket	(1)	96214-1	[B]
134	Flange Bolt (1/4" - 20 x 3")	(4)	96487	[SS]
135	Valve Block	(1)	96204	[PPG]
136	Plug, Large	(1)	96352	[D]
✓ 137	"O" Ring (1/16" x 1-5/8" o.d.)	(3)	Y325-29	[B]
✓ 138	"U" Cup Packing (1/8" x 1" o.d.)	(1)	94395	[U]
✓ 139	"U" Cup Packing (1/8" x 1-7/16" o.d.)	(1)	96383	[U]

### MATERIAL CODE

[B] = Nitrile	[PPG] = Glass Filled Polypropylene
[CK] = Ceramic	[SS] = Stainless Steel
[D] = Acetal	[SY] = Syn-Seal
[P] = Polypropylene	[U] = Polyurethane

### DIAPHRAGM PUMP SERVICE

#### GENERAL SERVICE NOTES:

- Inspect and replace old parts with new parts as necessary. Look for deep scratches on metallic surfaces, and nicks or cuts in "O" rings.
- Tools needed to complete disassembly and repair:
  - 5/8" socket or wrench, 7/16" socket or wrench, 3/8" socket or wrench, 5/16" Allen wrench, T-10 Torx screwdriver, torque wrench (measuring inch pounds), "O" ring pick.

### FLUID SECTION DISASSEMBLY

- Remove (61) top manifold.
- Remove (19) "O" rings, (21) seats and (22) balls.
- Remove (60) bottom manifold.
- Remove (19) "O" rings, (21) seats and (22) balls.
- Remove (15) fluid caps.
- Remove (6) diaphragm nut, (7) or (7 / 8) diaphragms and (5) washer.
- Remove (1) connecting rod from air motor.
- Carefully remove remaining (6) diaphragm nut, (7) or (7 / 8) diaphragms and (5) washer from (1) connecting rod. Do not mar surface of connecting rod.

### FLUID SECTION REASSEMBLY

- Reassemble in reverse order.
- Lubricate (1) connecting rod with Lubriplate or equivalent "O" ring lubricant.
- Install (5) washers with i.d. chamfer toward diaphragm.
- When replacing Teflon diaphragms, install the 96533-A Santoprene diaphragm behind the Teflon diaphragm.

Item	Description (size)	Qty	Part No.	[MTI]
140	Valve Insert	(1)	93276	[CK]
141	Valve Plate	(1)	96173	[CK]
✓ 144	"U" Cup Packing (1/8" x 3/4" o.d.)	(2)	Y187-47	[B]
✓ 166	"O" Ring (1/16" x 1-1/4" o.d.)	(1)	Y325-24	[B]
✓ 167	Pilot Piston (includes 168 and 169)	(1)	67382	[D]
168	"O" Ring (1/16" x 7/16" o.d.)	(2)	96459	[U]
169	"U" Cup Packing (1/8" x 5/8" o.d.)	(1)	96384	[U]
170	Spool Bushing	(1)	96090	[D]
✓ 171	"O" Ring (1/16" x 13/16" o.d.)	(2)	Y325-17	[B]
✓ 173	"O" Ring (3/32" x 7/8" o.d.)	(2)	Y325-115	[B]
✓ 174	"O" Ring (3/32" x 11/32" o.d.)	(2)	Y325-105	[B]
✓ 200	Porting Gasket	(1)	96364	[B]
✓ 232	"O" Ring (1/16" x 3/8" o.d.)	(4)	Y325-10	[B]
236	Nut (1/4" - 20)	(4)	Y12-4-S	[SS]
✓	Lubriplate FML-2 Grease	(1)	94276	
	Lubriplate Grease, 10 Pack		637308	

### AIR MOTOR SECTION SERVICE

- Service is divided into two parts - 1. Pilot Valve, 2. Major Valve.**
- Air Motor Section Service is continued from Fluid Section repair.

### PILOT VALVE DISASSEMBLY

- Remove (123) screws, releasing (103) covers, (121) washers, (118) actuator pins and (167) pilot piston.
- Remove (170) spool bushing and inspect inner bore of bushing for damage.

### PILOT VALVE REASSEMBLY

- Clean and lubricate parts not being replaced from service kit.
- Assemble (171) "O" rings to (170) bushing and assemble bushing into (101) center body.
- Lubricate and assemble (167) pilot piston assembly into (170) bushing.
- Assemble (173 and 174) "O" rings and (121) washers to (103) covers, then insert (118) actuator pins through assembly.
- Assemble (144) "U" cups (note the lip direction) and (103) covers to (101) center body, securing with (123) screws. NOTE: Tighten (123) screws to 4 - 6 in. lbs (0.45 - 0.68 Nm).

### MAJOR VALVE DISASSEMBLY

- Unthread (123) screws, releasing (129) muffler baffle.
- Unthread (134) bolts and pull (135) valve block and components from (101) center body.
- Remove (132) gasket, (141) valve plate and (140) valve insert from (135) valve block.
- Remove (134) bolts, releasing (107 and 136) plugs and (111) spool.

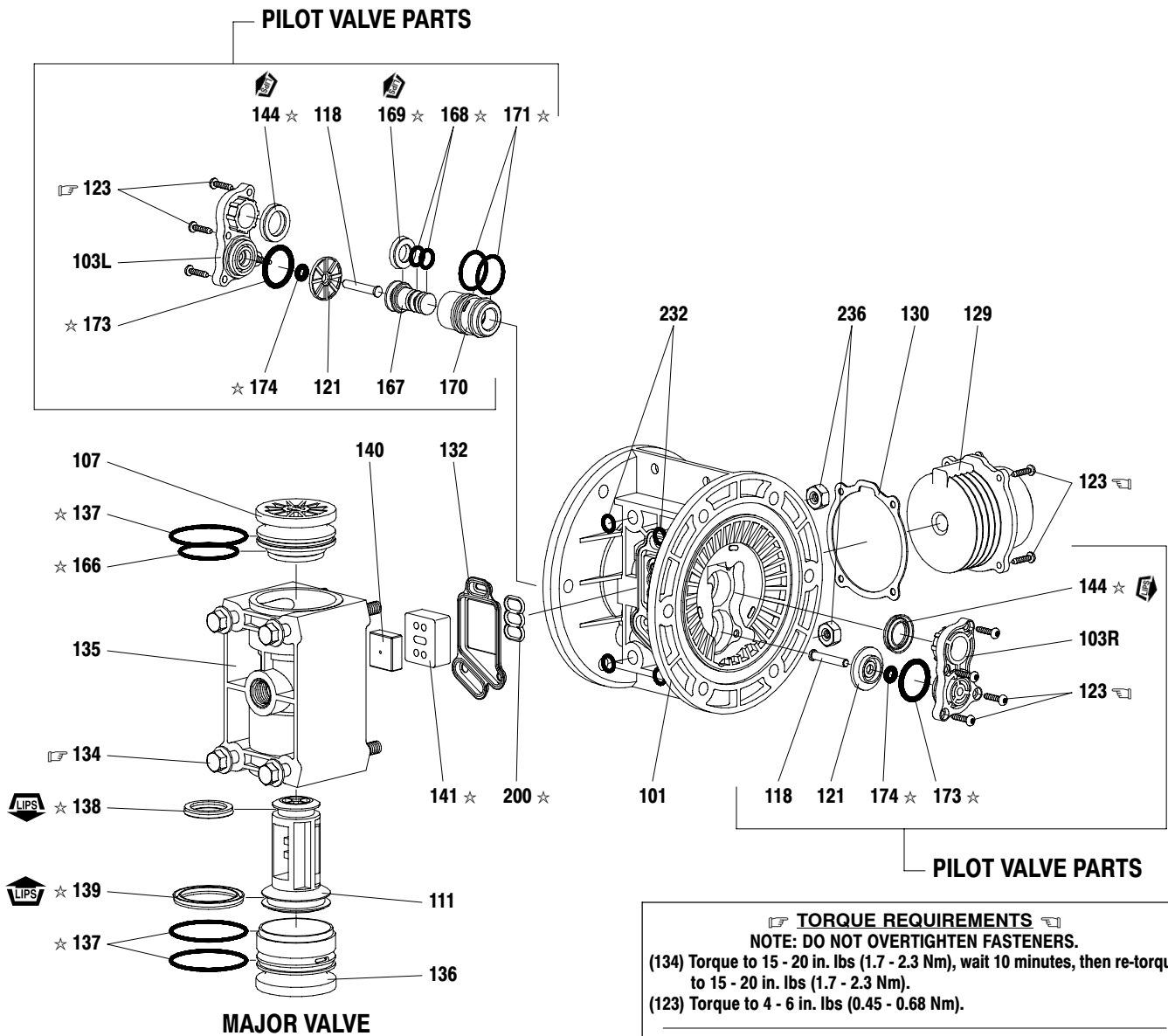

Figure 4

**MAJOR VALVE REASSEMBLY**

1. Assemble new (139 and 138) "U" cups on (111) spool - **LIPS MUST FACE EACH OTHER.**
2. Assemble (137) "O" rings to (136) large plug.
3. Assemble (137 and 166) "O" rings to (107) small plug.
4. Insert (111) spool into (136) large plug, then insert (136) large plug into (135) valve block, being sure the (111) spool is rotated to accept (140) valve insert.
5. Assemble (107) small plug into (135) valve block.
6. Assemble (140) valve insert and (141) valve plate to (135) valve block. Note: Assemble (140) valve insert with "dished" side toward (141) valve plate. Assemble (141) valve plate with identification dot toward (132) gasket.
7. Assemble (132 and 200) gaskets and (135) valve block to (101) center body, securing with (134) bolts. NOTE: Tighten (134) bolts to 15 - 20 in. lbs (1.7 - 2.3 Nm).
8. Assemble (130) gasket and (129) muffler baffle to (101) center body, securing with (123) screws. NOTE: Tighten (123) screws to 4 - 6 in. lbs (0.45 - 0.68 Nm).

## TROUBLE SHOOTING

### Product discharged from air exhaust.

- Check for diaphragm rupture.
- Check tightness of (6) diaphragm nut.

### Air Bubbles in product discharge.

- Check connections of suction plumbing.
- Check "O" rings between intake manifold and fluid caps.
- Check tightness of (6) diaphragm nut.

### Pump blows air out main exhaust when stalled on either stroke.

- Check "U" cups on (111) spool in major valve.
- Check (141) valve plate and (140) insert for wear.
- Check (169) "U" cup on (167) pilot piston.

### Low output volume.

- Check air supply.
- Check for plugged outlet hose.
- For the pump to prime itself, it must be mounted in the vertical position so that the balls will check by gravity.
- Check for pump cavitation - suction pipe should be sized at least as large as the inlet thread diameter of the pump for proper flow if high viscosity fluids are being pumped. Suction hose must be non-collapsible type, capable of pulling a high vacuum.
- Check all joints on intake manifolds and suction connections. These must be airtight.
- Inspect the pump for solid objects lodged in the diaphragm chamber or the seat area.

## DIMENSIONAL DATA

Dimensions shown are for reference only, they are shown in inches and millimeters (mm).

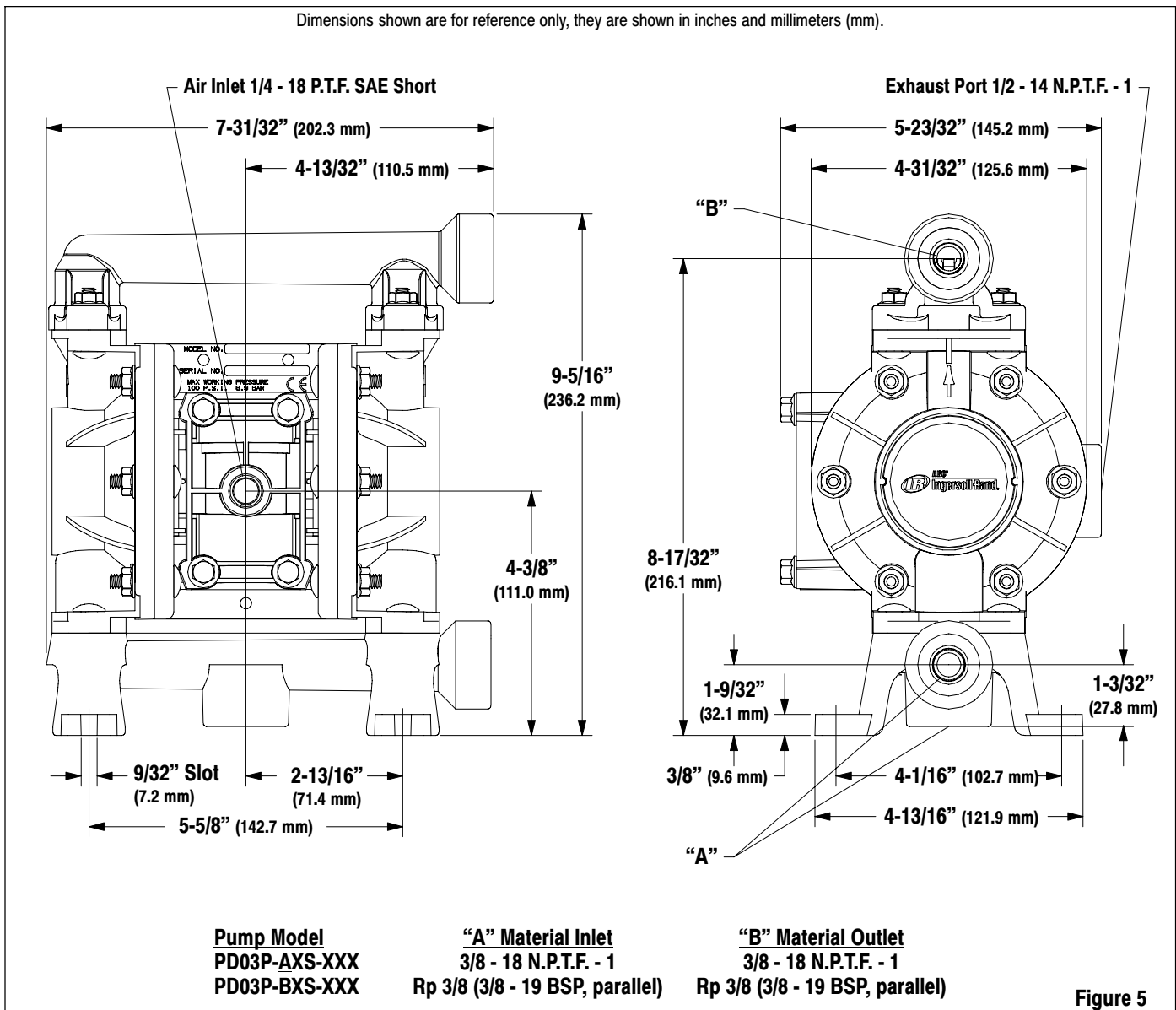



67388 WALL MOUNT BRACKET ASSEMBLY

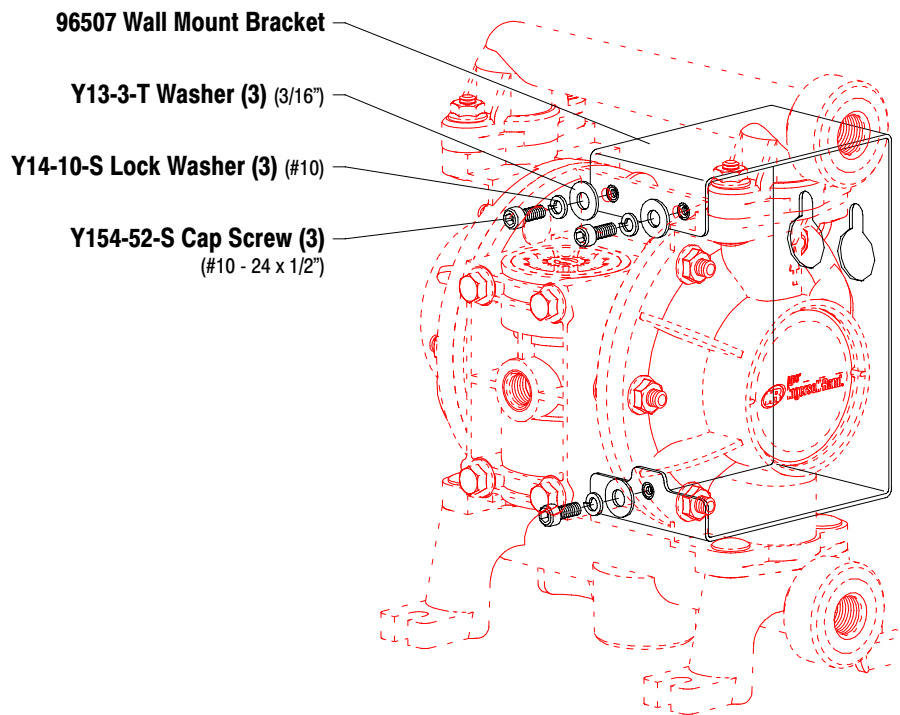

Figure 6





