

# Modèle: ALH 10

## Fiche technique

03/08/2007

**Poids 30,0Kg**  
**L.Tube 570,0 mm**  
**D.Tube 10,0 mm**

Dim.	mm
A	161,00
B	115,00
C	226,50
D	-
E	387,50
F	220,00
G	240,00
H	33,50
I	260,00
J	280,00
K	9,00
L	-
M	46,50
N	34,50
O	Insert cannelé $\varnothing 16$
P	64,50
Q	81,25

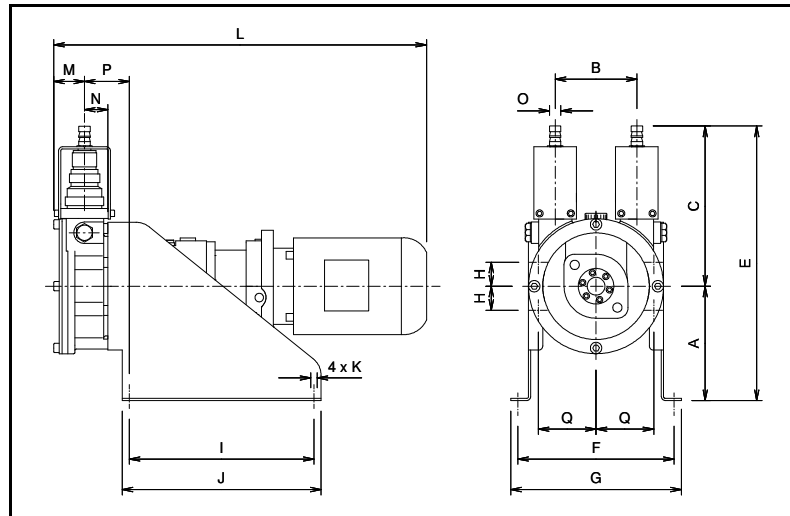

- Continu
- \*Intermittent
- Interdit

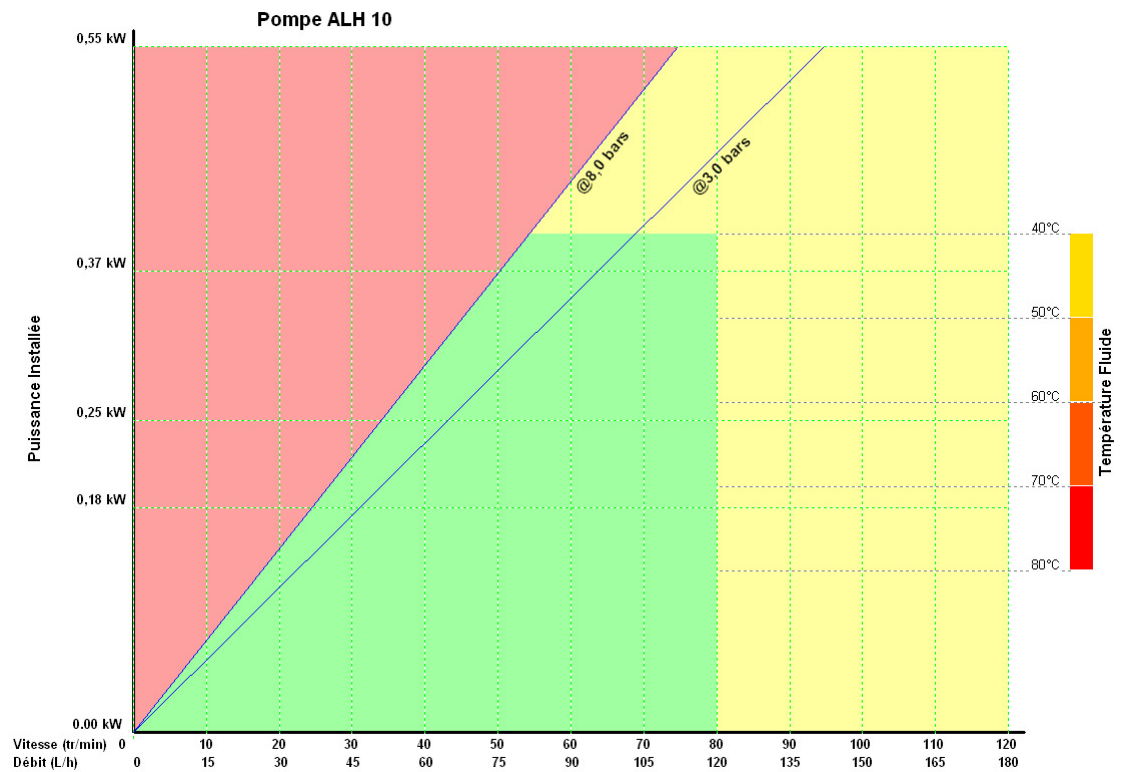

ALBIN PUMP SAS  
 ZAC de Fontgrave  
 F-26740 Montboucher  
 Tél: + 33 4 75 90 92 92  
 Fax: + 33 4 75 90 92 40  
[www.albinpump.fr](http://www.albinpump.fr)  
[www.albinpump.com](http://www.albinpump.com)

\*Usage intermittent: 2 heures max. en continu suivi de 1 heure d'arrêt