

Speciality Diaphragm Pumps – Selection chart
 Pompes spéciales à membranes – Table de sélection
 Bombas de membrana especiales – Tabla de selección
 Pompe a membrana speciali – Tabella di selezione

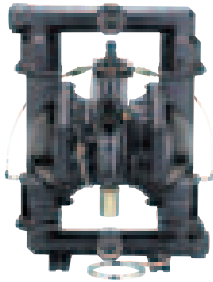

Page 56

PP Series

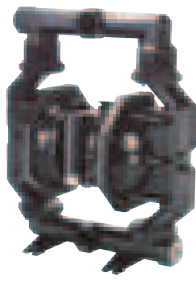

Page 58

PF Series

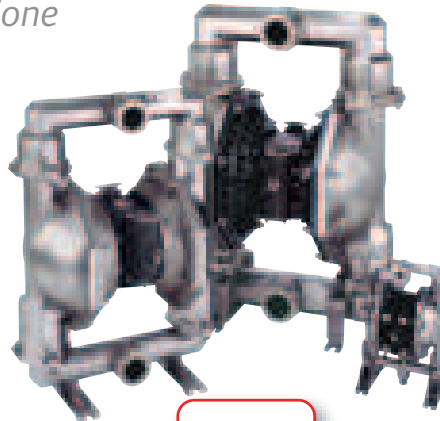

Page 60

PM Series

	Powder pumps Pompes à poudre Bombas de polvo Pompe di trasf. polveri		Flap valve pump Pompes à clapets Bomba con clapeta Pompa/valvola flap	Sanitary pumps Pompes sanitaires Bombas sanitarias Pompe Sanitarie				
?:1	1:1	1:1	1:1	1:1	1:1	1:1	1:1	1:1
∅	2"	3"	2"	1/2"	1"	1 1/2"	2"	3"
1 min. 	Max. powder density = 800 kg / m ³		651 l/min	49.2 l/min	198 l/min	465 l/min	651 l/min	1041 l/min
Max. 	6.9 bar (100 psi)	6.9 bar (100 psi)	8.3 bar (120 psi)	6.9 bar (100 psi)	8.3 bar (120 psi)	8.3 bar (120 psi)	8.3 bar (120 psi)	8.3 bar (120 psi)
	2" NPT 2" BSP	3" NPT 3" BSP	2" NPT 2" BSP	1 1/2" Tri-clamp	1 1/2" Tri-clamp	2" Tri-clamp	2 1/2" Tri-clamp	3" Tri-clamp
MATERIAL	Aluminium Stainless steel - Inox - Acero inox. Acciaio inox		Aluminium Cast iron - Fonte - Hierro fundido - Ghisa Stainless steel	FDA accepted materials Matériaux agréés FDA Materiales aprobados por la FDA Materiali approvati FDA (non soddisfa le esigenze 3-A, USDA o EHDEG)				
	41.5 kg (aluminium) 71.6 kg (stainless steel)	62.4 kg (aluminium) 107.4 kg (stainless steel)	44.2 kg (aluminium) 75.4 kg (cast iron) 75.3 kg (stainless steel)	6.7 kg (polypropylene/ stainless steel)	20.1 kg	28.1 kg	64.8 kg	103.2 kg
			17.3 kg		27.3 kg	71.4 kg	114.9 kg	
			23.2 kg		35.3 kg	77.9 kg	121.2 kg	
Max. 	6.4 mm	9.5 mm	51 mm (semi-solids)	2.4 mm	3.3 mm	6.4 mm	6.5 mm	9.5 mm
ATEX certified 	All models Tous les modèles Todos los modelos Tutti i modelli		With aluminum or stainless steel motor Avec moteur alu. ou inox Con motor de aluminio o acero inoxidable Con motore in alluminio o acciaio inox	With aluminum or stainless steel motor Avec moteur alu. ou inox Con motor de aluminio o acero inoxidable Con motore in alluminio o acciaio inox				



Page 62

Pit Boss Series

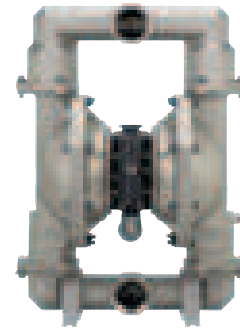
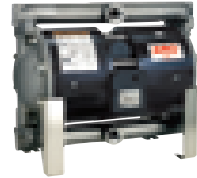

Page 64

PH Series

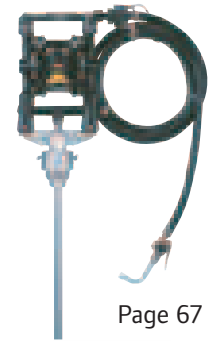

Page 67

DAB05 Series

	Dewatering Pumps Pompes d'épuisement Bombas de achique Pompe per il trasferimento di acque			High pressure pumps Pompes haute pression Bombas de alta presión Pompe alta pressione				Drum pumps Pompes pour fûts Bombas para bidón Pompe per fusto
?:1	1:1	1:1	1:1	3:1	2:1	2:1	2:1	1:1
Ø	1 1/2"	2"	3"	1"	1 1/2"	2"	3"	1/2"
1 min. 	303 l/min	590 l/min	820 l/min	50 l/min	238 l/min	348 l/min	605 l/min	45.4 to 54.5 l/min
Max. bar	8.3 bar (120 psi)	8.3 bar (120 psi)	8.3 bar (120 psi)	6.9 bar (100 psi)	6.9 bar (100 psi)	6.9 bar (100 psi)	6.9 bar (100 psi)	6.9 bar (100 psi)
	1 1/2" BSP	2" BSP	3" BSP	1" NPT 1" BSP	1 1/2" NPTF 1 1/2" BSP 1 1/2" ANSI/DIN	2" NPTF 2" BSP 2" ANSI/DIN	3" NPTF 3" BSP 3" ANSI/DIN	1/2" NPT 1/2" BSP
MATERIAL	Aluminium	Aluminium	Aluminium	Stainless steel Acier inox Acero inox. Acciaio inox	Stainless steel Acier inox Acero inox. Acciaio inox	Stainless steel Acier inox Acero inox. Acciaio inox	Stainless steel Acier inox Acero inox. Acciaio inox	Polypropylene Aluminium Stainless steel
	25.2 kg	33.6 kg	53.7 kg	43 kg	39.9 kg	66.2 kg	121.6 kg	—
Max. 	12.7 mm	19.1 mm	25.4	3.2 mm	6.4 mm	6.4 mm	9.5 mm	2.4 mm
 ATEX certified	All models Tous les modèles Todos los modelos Tutti i modelli			All models Tous les modèles Todos los modelos Tutti i modelli				Metallic pumps with aluminum motor Pompes métal. avec moteur aluminium Bombas metálicas con motor de aluminio Pompe metalliche con motore in alluminio

3